

*Model 6500*

# *Refrigerated Glassfront*

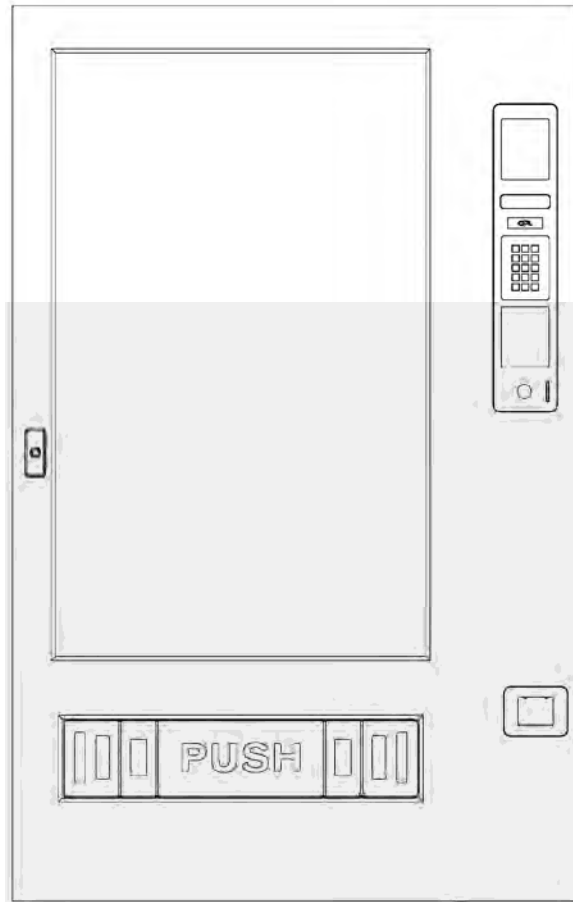

## **Set-Up / Programming / Parts Guide**

**PLEASE**

**DO NOT REMOVE  
MANUAL FROM  
MACHINE**



**GPL ♦ 165 Bridgepoint Drive ♦ South St. Paul MN 55075**



## TABLE OF CONTENTS

Warranty.....	iii
Introduction.....	iv
Features.....	iv
Specifications.....	v
Installation.....	1.01
Cautions.....	1.01
Unpacking.....	1.02
Leveling the Machine.....	1.02
Door Hinge.....	1.03
Set Up Steps.....	1.04
Optional Equipment.....	2.01
Refrigeration.....	2.02
Components.....	3.01
Power Supply.....	3.01
Lighting System.....	3.01
Main Product Shelves.....	3.01
Delivery Bin.....	3.01
Vend Motors.....	3.02
Logic Board & Display.....	3.03
Keypad.....	3.03
Coin Mechs, Validators and Card Readers.....	3.03
PosiVend™.....	3.04
Operating System.....	4.01
Power Up State.....	4.01
Motor Scan.....	4.01
Standby.....	4.01
Keypad.....	4.01
Credit Accumulation.....	4.01
Vend Process.....	4.02
Change Payback.....	4.02
Use Correct Change.....	4.02
Token Vends.....	4.02
Accountability Information.....	4.02
Shutdowns.....	4.02
DEX/UCS.....	4.02
Programming.....	5.01
Service Modes.....	5.03
Parts.....	6.01
Service/Trouble Shooting.....	7.01

To achieve the most trouble-free operation from your Fusion Merchandiser, it is highly recommended that this service manual be thoroughly read and the instructions followed pertaining to installation, servicing and maintaining of the unit.

Should you have questions pertaining to this manual or the vendor, please contact your GPL distributor or write directly to:

Product Support Group  
GPL  
165 Bridgepoint Drive  
St. Paul, MN 55107 USA  
651-288-2975 or 800-523-5932  
651-288-2971 (fax)  
www.cranems.com  
© 2007 GPL

## LIMITED EXPRESS WARRANTY

GPL warrants these automatic merchandisers (the "Unit"), manufactured by it, to be free under normal use and service from defects in material or workmanship for a period of two (2) years from the date of delivery of this Unit to the original purchaser who purchased the Unit either directly from GPL or from an authorized GPL dealer or distributor ("GPL Dealer/Distributor"). This warranty extends only to the original purchaser of the Unit, but only if purchased either directly from GPL or from an authorized GPL Dealer/Distributor ("Original Purchaser"), and is limited to the repair or replacement, at GPL's sole option, of any part or parts of the Unit that are returned to GPL or to the authorized GPL Dealer/Distributor from whom the Unit was originally purchased, with all transportation charges prepaid by Original Purchaser, and which, on GPL's examination, such returned part or parts shall conclusively appear to have been defective. This warranty does not extend to:

1. Any Unit, or part thereof, that was subjected to misuse, neglect, or accident by anyone other than GPL after its delivery to the Original Purchaser;
2. Any Unit, or part thereof, that was modified, altered, incorrectly wired or improperly installed by anyone other than GPL or used in violation of the instructions provided by GPL;
3. A Unit, or part thereof, which has been repaired or altered by anyone other than GPL or an authorized GPL Dealer/Distributor;
4. A Unit, or part thereof, which has had the serial number removed, defaced, or otherwise altered;
5. Any plastic or glass windows, lamps, fluorescent tubes, and water contact parts;
6. Any Unit used outdoors;
7. Any accessories used with the Unit that were manufactured by some person or entity other than GPL; or
8. Any Unit repaired within the warranty period with parts other than genuine GPL built or endorsed parts.

**GPL DISCLAIMS ALL OTHER WARRANTIES OF ANY KIND AS TO THE UNIT AND ALL WARRANTIES OF ANY KIND AS TO ANY ACCESSORIES. THIS DISCLAIMER OF WARRANTIES INCLUDES (1) ANY EXPRESS WARRANTIES OTHER THAN THE LIMITED WARRANTY PROVIDED ABOVE AS TO THE UNIT AND (2) ALL IMPLIED WARRANTIES OF MERCHANTABILITY AND FITNESS FOR A PARTICULAR PURPOSE AS TO THE UNIT AND ANY ACCESSORIES. UNDER NO CIRCUMSTANCES SHALL GPL BE RESPONSIBLE FOR ANY INCIDENTAL, CONSEQUENTIAL OR SPECIAL DAMAGES, LOSSES OR EXPENSES (INCLUDING BUT NOT LIMITED TO LOST PROFITS, LOST SALES, INJURY TO PERSON OR PROPERTY) ARISING FROM OR IN CONNECTION WITH THE USE OF, OR THE INABILITY TO USE, THE UNIT FOR ANY PURPOSE WHATSOEVER REGARDLESS OF THE LEGAL THEORY (CONTRACT, TORT OR OTHER). IN NO EVENT WILL GPL BE OBLIGATED TO PAY DAMAGES FOR ANY AMOUNT EXCEEDING THE PRICE PAID FOR THE UNIT.** No representative of GPL or any other person is authorized to assume for GPL, or agree to on the behalf of GPL, any other liability or warranty in connection with the sale of this Unit.

GPL reserves the right to make any changes or improvements in its products without notice and without obligation, and without being required to make corresponding changes or improvements in Units theretofore manufactured or sold.



165 Bridgepoint Drive  
South St. Paul, MN 55075 USA  
651-288-2975  
651-288-2971 (fax)

## INTRODUCTION

The Fusion features simple operation and built in flexibility, as well as extensive diagnostics and error reporting facilities to provide ease of maintenance.

## HOW TO USE THIS MANUAL

This manual is divided into seven basic parts:

1. Unpacking and Installation.
2. Optional Equipment & Refrigeration
3. Components and Refrigeration.
4. Operating System.
5. Programming
6. Parts
7. Troubleshooting.



**CAUTION:** Certain procedures in both the operating section and the service section require that voltage be on in the machine. Only, trained personnel should perform this function. Exercise extreme caution while performing these procedures. These procedures will be marked with the lightening bolt symbol as it appears at left.



**CAUTION:** Certain procedures in both the operating section and the service section require a qualified trained technician to perform the particular task at hand. These procedures will be marked with the exclamation symbol as it appears at left.

# Features

---

## FEATURES OF THE FUSION MERCHANDISER

### STANDARD FEATURES

- Up to 100 selections.
- Multi drop buss capabilities (MDB).
- Extensive diagnostics capabilities.
- Friendly text-based interface.
- Flexible spiral spacing for large products.
- Eight-point star drive motor.
- Dex/UCS compatible.
- Food/Frozen hosting.
- Real time clock.
- Machine reset capability.
- Chime.
- Third payment system ready.

### PRICING

- Global pricing by machine or by shelf.
- Extensive accountability, including all discounts and free vends.
- Shutdown capabilities
- Combo vends.
- Programmable spiral count.
- Upload and download capabilities for pricing and set up.
- Programmable maximum payout.

### SCROLLING DISPLAY

- User friendly two-line scrolling display to help with the selection process and provide customer feedback.
- User programmable point of sale and operational messages.
- 2 line display with 20 characters on each line.

### NOISE LEVEL

Operates at less than 70 db (A).

### ACCEPTABLE AMBIENT OPERATING TEMPERATURE RANGE.

All equipment manufactured by GPL is designed to work properly in a temperature range of 10°C to 38°C (50°F to 100°F) in still air (75% R.H. non-condensing). The machine is capable of being stored in a temperature range of -18°C to 68°C (0°F to 155°F).

# Specifications

<b>Fusion Specifications</b>	<b>Domestic</b>	<b>Export</b>
Height	72" / 183 cm	72" / 183 cm
Width	41.5" / 113 cm	41.5" / 113 cm
Depth	37.375" / 95 cm	37.375" / 95 cm
Floor Space	10.77 Sq. Ft./ 1 Sq Meter	10.77 Sq. Ft./ 1 Sq Meter
Container Size		
Voltage (AC)	120V	230V
Hertz	60Hz	50Hz
Standby Amperes		
Running Amperes		
Watts		
Refrigerant Type	134A	134A
Refrigerant Charge	9.8 oz / 0.28 Kg	
High Side Test Pressure		
Low Side Test Pressure		
Shipping Weight	693 lbs / 315 kg	

<b>SNACK/FOOD SPIRALS</b>	<b>CANDY SPIRALS</b>	<b>BOTTLE SPIRALS</b>
<b>6 – Item Spiral 3-3/32"</b>	<b>6 – Item Spiral 2-7/8"</b>	<b>6 – Item Spiral 2-7/8"</b>
<b>10 – Item Spiral 1-7/8"</b>	<b>15 – Item Spiral 1-1/8"</b>	
<b>12 – Item Spiral 1-9/16"</b>	<b>18 – Item Spiral 15/16"</b>	
5 - Item Spiral 4-1/8"	5 – Item Spiral 4-1/8"	
7 – Item Spiral 2-21/32"	7 – Item Spiral 2-1/2"	
15 – Item Spiral 1-7/32"	9 – Item Spiral 1-15/16"	
18 – Item Spiral 1"	10 – Item Spiral 1-3/4"	
30 – Item Spiral 1/2"	12 – Item Spiral 1-1/2"	
40 – Item Spiral 5/16"	24 – Item Spiral 11/16"	
	30 – Item Spiral 1/2"	
	40 – Item Spiral 3/16"	

### **SPIRAL DEPTH CHART**

**Spirals highlighted in bold are standard production spirals.  
All other spirals are available through aftermarket parts only.  
Measurement indicates maximum product thickness.**

# Specifications

Machines are available with the spiral assortment shown below.  
 Figures in circles represent capacities of each spiral.

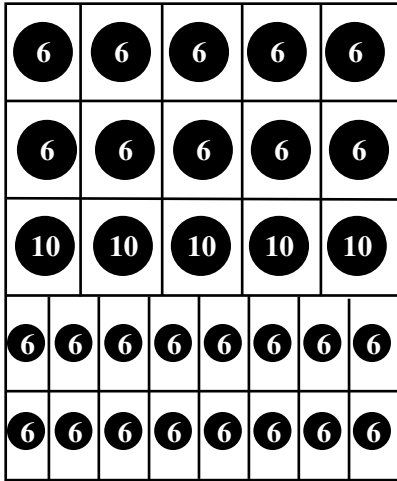

**3-2 Food/Bottle**  
 110 Food Capacity  
 96 Bottle Capacity  
 206 Total Capacity

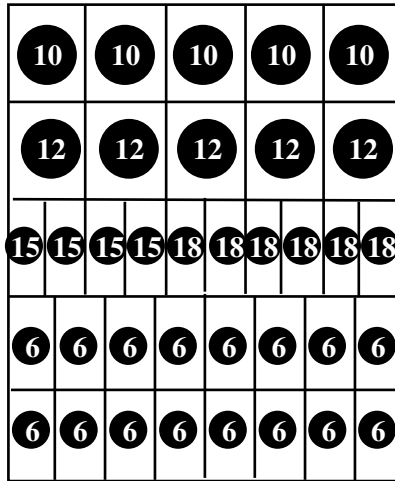

**2-1-2 Snack/Candy/Bottle**  
 110 Snack Capacity  
 168 Candy Capacity  
 96 Bottle Capacity  
 374 Total Capacity

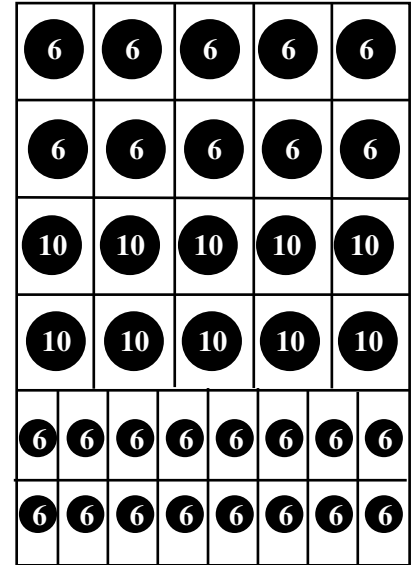

**4-2 Food/Bottle**  
 80 Food Capacity  
 96 Bottle Capacity  
 176 Total Capacity

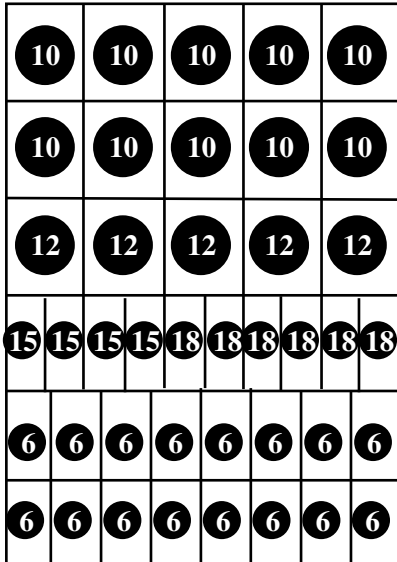

**2-1-1-2 Snack/food/Candy/Bottle**  
 100 Snack Capacity  
 60 Food Capacity  
 168 Candy Capacity  
 96 Bottle Capacity  
 424 Total Capacity

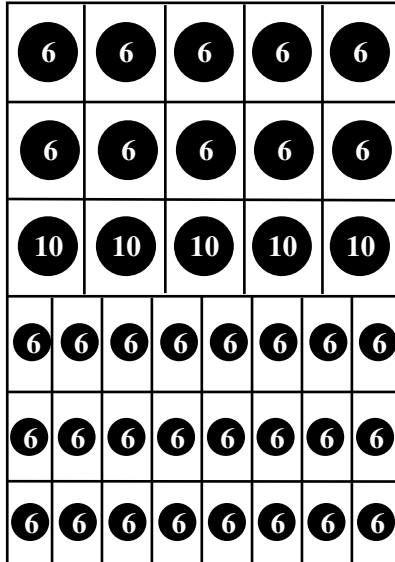

**3-3 Food/Bottle**  
 70 Food Capacity  
 144 Bottle Capacity  
 214 Total Capacity

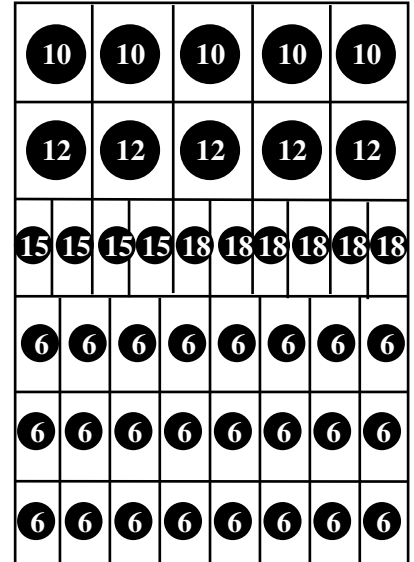

**2-1-3 Snack/Candy/Bottle**  
 110 Snack Capacity  
 168 Candy Capacity  
 144 Bottle Capacity  
 422 Total Capacity



# Installation

## Cautions

The following cautionary information should be reviewed before the machine is installed. Following these requirements and warnings are required.



**CAUTION:** This machine is designed for indoor usage only. Any other usage will void the Manufacturers Warranty.



### Voltage and Polarity Check

It is important that this machine is hooked up to the proper voltage and polarity for your country. Use a voltmeter to verify voltage and polarity **before** connecting the machine to a wall outlet. For machines located in North America, use the diagram below to verify correct voltages.



**CAUTION:** Any procedure marked with the symbol at left requires that the Machine have the power applied and a shock hazard exists.



**CAUTION:** It is important that this machine is hooked up to the proper voltage and polarity for your country. Use a Voltmeter to verify voltage and polarity. Should the reading be any different than a normal reading or if you are unsure of what the reading should be contact an electrician.



**CAUTION:** Different countries may have unique plug arrangements. Ensure that the machine is properly grounded before operating.



**CAUTION:** The power cord for all machines manufactured for use outside of North America are of a type Y attachment. If the power cord is damaged, it must be replaced by the manufacturer, its service agent, or a similarly qualified person in order to avoid a hazard.



**CAUTION:** The machine is a heavy item. Ensure that sufficient personnel are available for lifting and transporting the machine. Use proper lifting procedures and equipment.



**CAUTION:** The system components in this machine utilize static sensitive components. Precautions for handling sensitive devices should be observed when handling these items.

## Voltage and Polarity Check (for Machines located in North America Only)

It is important that this machine is hooked up to proper voltage and polarity. Using a voltmeter, perform the following checks from the illustration below.

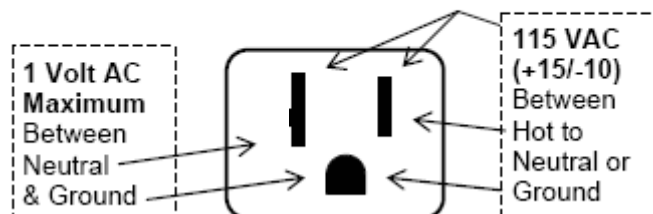

# Installation

The Fusion Line is assembled and packed so that a minimum amount of time is necessary for preparation to install it on location. The following steps are recommended to insure correct unpacking.

1. **Shipping Damage:** Thoroughly inspect the exterior of the carton for damage which may have occurred during shipment. Report any damage to delivering carrier and follow their instructions.
2. Remove the remainder of the packing material. On machines shipped with the lock in place, the keys are taped inside the coin return.

**NOTE:** On the machine, the weight concentration is toward the back of the cabinet. Trucking and lifting should be done from the back. CAUTION should be taken when trucking from side.

3. On machines with lock in place, first unlock and turn handle to open door. When no lock is furnished, remove clip and turn handle. Swing door to its full open position.
4. Remove all additional packing material from the machine.
5. **Warranty:** The warranty card is attached to the cover of this manual. It must be filled out in full and mailed at once to insure coverage.

**Leveling the Machine** on location is important for the proper function of the machine. There are four leveling screws in the legs of the machine to make any necessary adjustments. After positioning the machine, level it from front to rear and right to left directions. After leveling, turn front right (lock side) leveling screw in about one-half turn to drop this corner slightly to make the door easier to close and lock.

## Clearance Requirements

It is necessary on Fusion machines to have 6" clearance behind the machine for air circulation.

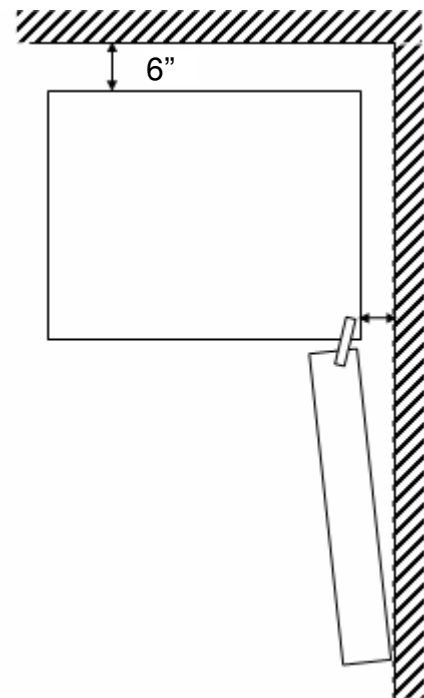
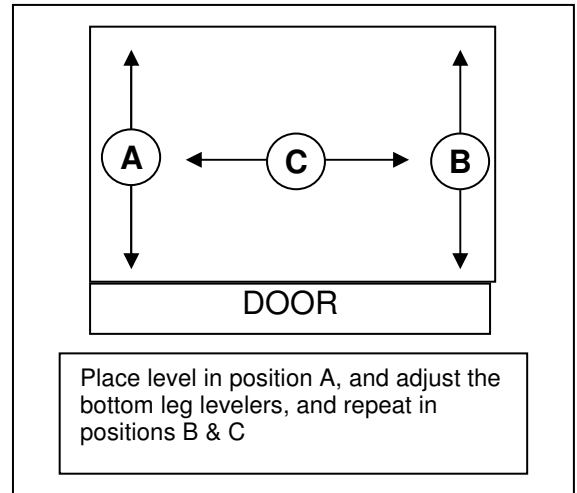

◆ **IMPORTANT:** A set of anchoring brackets is included with each machine. This kit is located in the bottom of the machine with complete instructions. It is recommended that this kit be installed during set-up to prevent shifting of the machine.

# Installation

## Door Hinge Swing

This machine contains a newly designed door hinge. The design of the door hinge controls the maximum distance the door can swing open. The maximum opening position is reached when the screw is forced against the hinge body. This screw can be removed during installation to permit the door to swing completely open and can help maneuver the machine through a narrow doorway.

The screw should be replaced **immediately** upon reaching the machine's final location. Failure to replace this screw may result in damage to an adjacent machine or to the harnesses in the machine.

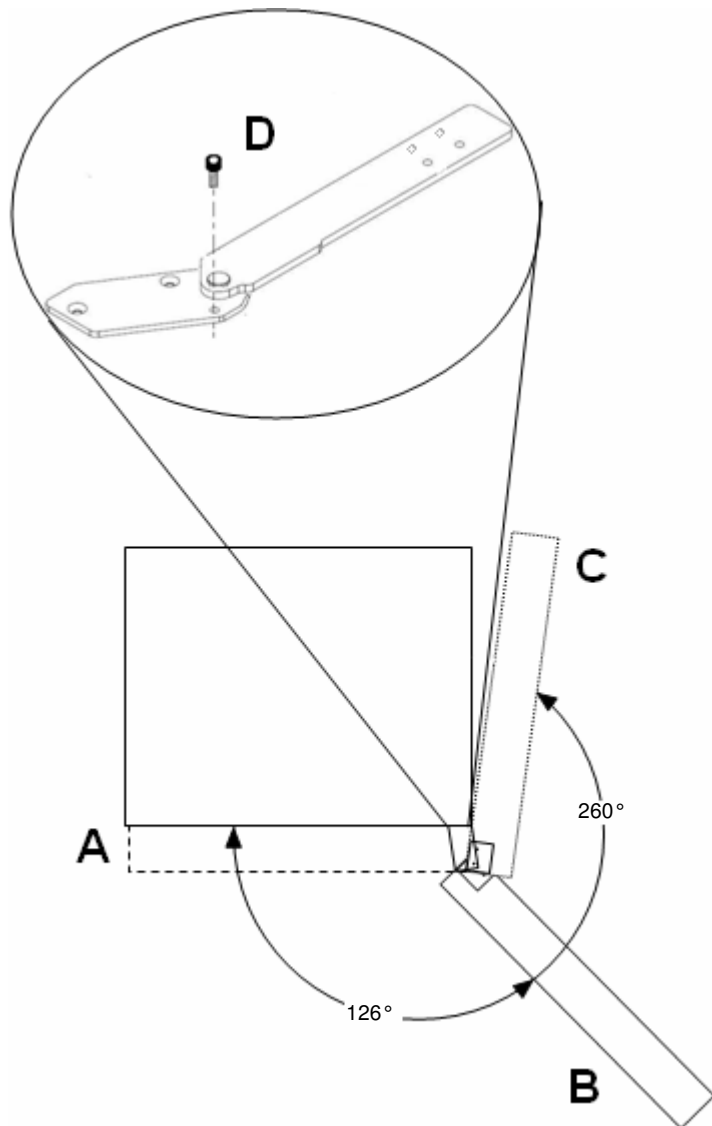

**Position A** – Door Closed.

**Position B** – Door open to nominal position with stop screw (D) installed.

**Position C** – Stop screw removed to permit door to reach maximum swing.



**CAUTION:** The screw should be replaced immediately upon reaching the machines final location. Failure to replace this stop may result in damage to an adjacent machine or the harnesses in the machine.

# Installation

## Basic Set Up Steps

1. Remove all packing materials.
2. Adjust the scrolling price tabs on the shelves.
3. Set prices and options on control board.
4. Set Clock.
5. Load machine adjust spacers or spirals as needed.
6. Install product pushers as needed.
7. Add coins to coin mechanism.
8. Coin test.
9. Bill test if applicable.
10. Install lock cylinder if needed.

## Loading Snack Shelves

Open the main door to its full open position. While pushing down on the plastic lock lever located on the right side of the shelf, grasp the shelf under both front corners (see Figure 1). Lift the front of the shelf slightly and pull forward until the shelf reaches its stop. On shelves 1 through 4 the shelves tilt down (do not drop) to make loading easier. A new feature in the Fusion, the bottom 2 shelves do not tilt for easier loading. Only one product shelf should be in the loading position at any time. When returning a shelf, be sure the shelf is in its full home or vend position. Begin loading with the top shelf. Move it into the loading position. The height spacing for items is greatest in this shelf and the tallest bagged items should be placed there. Soft items, such as pastry, pies, etc., should be placed in the lowest snack shelf, making the drop distance as short as possible.

**IMPORTANT:** Product must not be forced into the spiral spaces it should fit freely. If a product fits tightly, use a larger pitch spiral. The bottom of the product should be placed on top of the spiral wire that rests on the shelf surface (see Figure 2). The width of the product must be greater than the diameter of the snack spiral. If it is smaller, the product may fall through when it is in the front, ready to vend position.



Figure 1: Moving shelf into the loading position

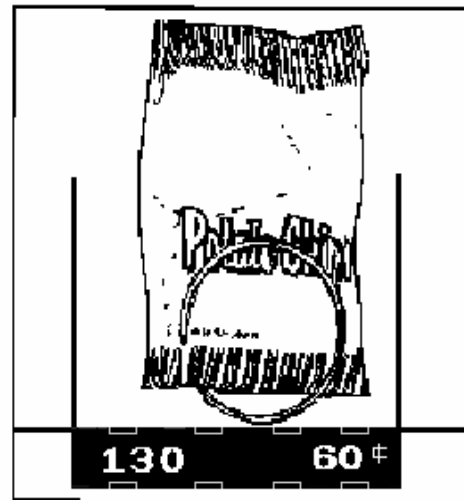

Figure 2: Placement of product on main product snack shelves and front end position of spiral.

# Installation

## Adjusting the Stopping Position of the Spiral

One primary difference that distinguishes the Fusion motor from previous motors is an eight sided star at the drive hub of the motor. This permits the stopping position of the spiral to be customized by the operator to ensure the best possible delivery of each product. To change the stopping position of the spiral, remove the spiral lock from the motor by pinching the shaft of the spiral lock from the back side of the motor and pulling forward on the front side of the spiral lock. The spiral lock can be reinstalled in any of eight different positions by turning the spiral lock to the position desired and pushing the shaft of the spiral lock through the eight sided star at the drive hub of the motor.

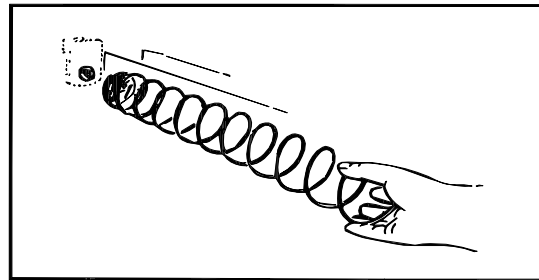

Figure 3: Removing and installing spiral.

## Removal/Replacement of Spiral

**Right Hand Spirals:** Grasp the front of the spiral and turn it clockwise. Lift the spiral up and off of the spiral lock. When replacing a spiral attach it around the tab on the spiral lock and turn the spiral counterclockwise to lock it in place (see figure 3). Pull lightly on the front of the spiral to ensure it is locked in place.

**Left Hand Spirals:** Grasp the front of the spiral and turn it counter clockwise. Lift the spiral up and off of the spiral lock. When replacing a spiral attach it around the tab on the spiral lock and turn the spiral clockwise to lock it in place. Pull lightly on the front of the spiral to ensure it is locked in place.

## Product Spacers - 5 Selection Shelf

A product spacer is used to reduce the width of the product area. This feature should be used on any 5-selection single spiral snack shelf where the product width is 4" or less. Spacers should fit within 1/8" of the product but should not fit tight against the product. There are three positions in each snack space where these spacers can be placed. To install the spacer, align the lock ears (on the lower edge of the spacer) with one of the three sets of slots (one front and one rear). (see Figure 4.) Push the spacer to the rear to allow the ears to enter the slots, then allow the spacer to move forward. Be sure the ears are in the same set of slots, front and rear (see Figure 4). Continue loading all spirals; adjust spacers where needed in the top shelf. Return the top shelf to the vend position and follow this procedure to load the remainder of the large spiral shelves.

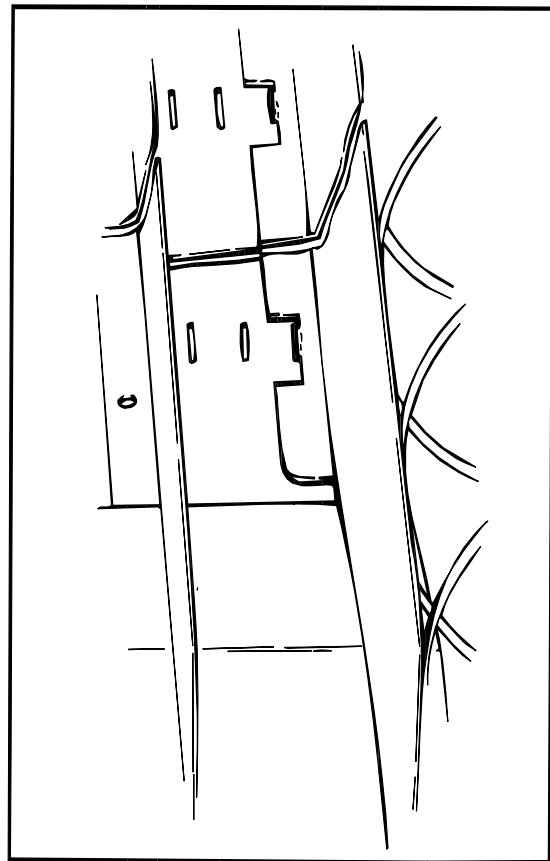

# Installation

## Loading Main Product Candy Shelves

The 10-selection (candy type) shelves are loaded similarly to the 5-selection shelves except that the bottom of the product sits on the shelf in front of the spiral wire (see Figure 5). These products must also fit properly, and the product should fit freely: do not force product into spiral.

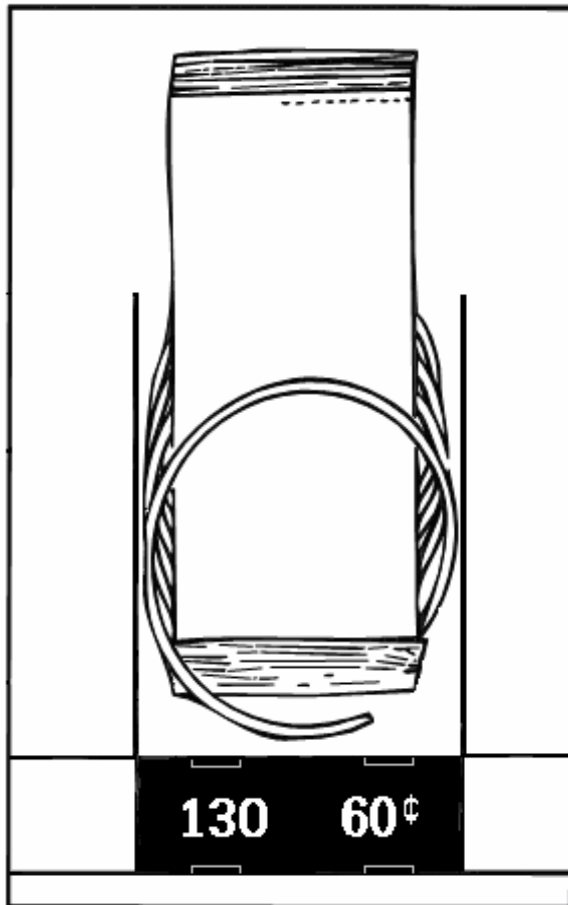

Figure 5: Placement of product on candy shelves and front end position of spiral.

## Product Spacers-10 Selection Shelf

The 10-selection shelves are equipped with a product spacer (see Figure 6) that can be pivoted from the right side of every other product space. These spacers should be pivoted out to hold the product upright, but not tight against the product. Leave about 1/8" clearance between the spacer and the product.

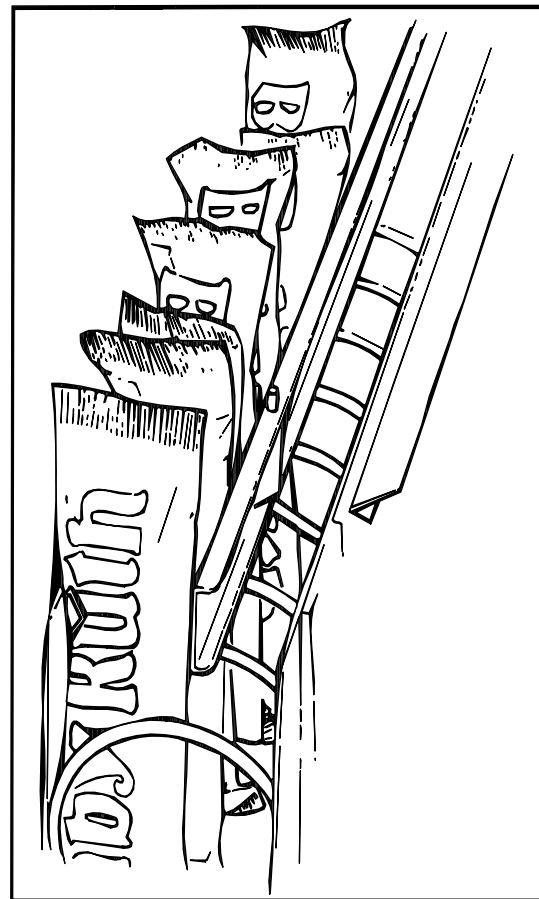

Figure 6: Candy shelf product spacer positioned to hold candy upright.

# Installation

## Product Pushers

Included with the machine are enough pushers for you to install a pusher on each candy spiral. This plastic part is designed to push the top of the product forward while it is vending, helping it fall from the shelf. It can also be used with products that have the wrapper end flap on the outside of the package. In this case, the pusher prevents these products from hanging on the spiral by spreading the flap. The pusher should be installed at approximately the 1 o'clock position on the spiral with the tab extending forward (see Figure 7). Locate the pusher in its proper position, hold it against the spiral wire and push the semi-circular part around the spiral wire. Black pushers (#440215) are used on left hand spirals and white pushers (#44014-1) are used on right hand spirals. Black pushers are used on left hand spirals Note: Not every selection spiral will need a product pusher. (Example - Box Items.)

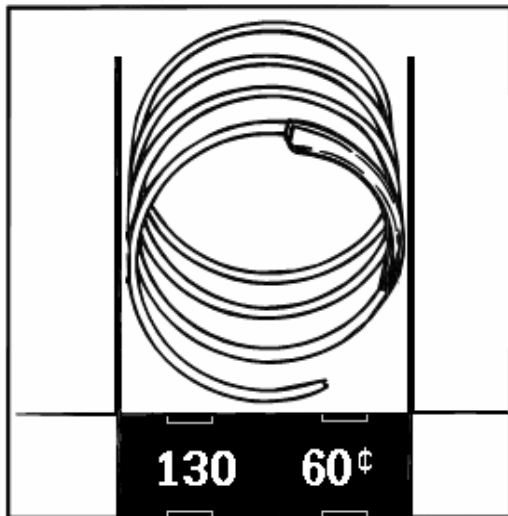

Figure 7: Location of product pusher on spiral.

## Bagged or Boxed Items

Vending small bagged items in the 10-selection shelves if not loaded properly could be a problem. The sealed edge of the bag may get under the spiral wire causing the product to hang up after it has been vended. It is recommended that the lower edge of these types of product be folded forward and up (see Figure 8) next to the product before inserting into the spiral space. It is also recommended to use a slightly larger count spiral for bagged items because of the product settling to the bottom of the package.

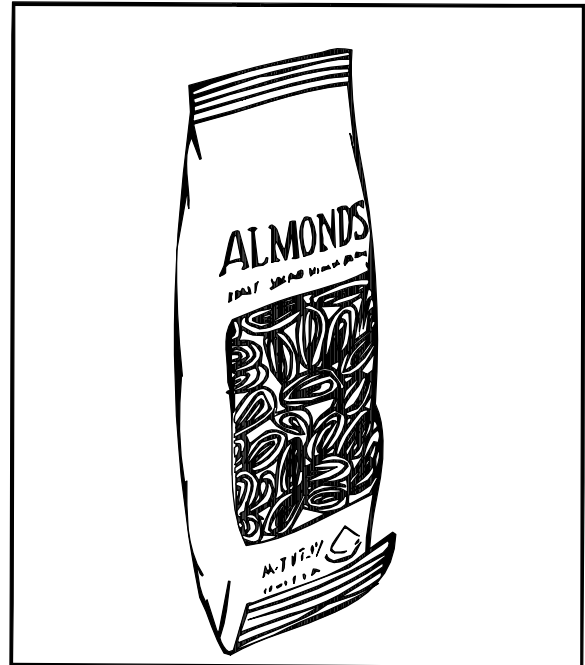

Figure 8: Fold bagged items bottom edge forward and up.

## Cigarette Vending From the Fusion

Cigarettes can be vended from the candy shelves using a (15 capacity) spiral for the soft pack regular, king, 100 MM or 120 MM packs. A (12 capacity) spiral should be used for (box) packs.

## Lock Product Shelves

When all of the product has been loaded be sure all shelves are returned to their vend position behind the front roller guide.

## Scrolling Price Tabs

Adjust the new scrolling price roles for each selection in the machine.

# Installation

---

## **Cleaning**

The Fusion will do the best merchandising job for you if it is kept clean. The display window can be cleaned with any good glass cleaner. The exterior and interior surfaces should be cleaned with warm water and mild detergent. Rinse thoroughly and dry all surfaces.

**CAUTION:** Do not use any cleaners containing silicon as this could cause electrical failures.

The main product shelves can be best cleaned with the spirals and product spacers removed. Refer to page 1.05 for removal of spirals and removal of the product spacers.

Clean the acceptor on the coin mechanism or bill validator frequently as accumulated dirt in this area can cause poor acceptance on coins or bills. Follow recommended cleaning procedures as described by the coin mechanism or bill validator manufacturer.



# Optional Equipment

---

## **Dual Spiral Motors** (Part # 360240)

Snack shelves can be set up to have dual spiral selections. The dual spirals will help vend specialty items better. **These motors are available through aftermarket parts only.**

## **Half Cycle Motors** (Part #360241)

The half cycle motors are used to vend thin items. This motor is used with a product divider that is positioned down the center of the coil. The product is placed on both the left and right hand side of the coil. When the motor turns, it turns only 180 degrees (half revolution) rather than 360 degrees (full revolution). **These motors are available through aftermarket parts only.**

## **Touch Memory Harness**

The touch memory harness (Part # 16800013) is used in conjunction with the touch memory button (CHIP) available separately (Part # 17500003). This harness will allow you to download all settable data, with the exception of the time and date. Once CHIP is programmed you can take it to as many machines as you wish to upload the information stored in CHIP. CHIP can be programmed from a machine that is already set up and then used to set up other machines that are to be programmed identically. For more information see Mode 30.

# Refrigeration

---

## The Refrigeration Unit

The Refrigeration Unit is comprised of a 1/3 horsepower compressor and is a hermetically sealed system (no service ports). The refrigerant used in the refrigeration system is 134a and the charge is 9.8 ounces. The refrigeration system is controlled by the Refrigeration Driver Board. The Fusion glassfront merchandisers are designed to operate at ambient temperature of 55°F to 100°F (13°C to 38°C).

## Refrigeration Processing:

The Refrigeration Driver Board (P/N 80492751) maintains the temperature as measured by the solid state temperature sensor. The refrigeration unit will be turned on at the Set Temperature plus 3°F and will be turned off at the Set Temperature minus 3°F.

A minimum of 1 minute is required for both the cycle-on and cycle-off time of the relay. This insures the compressor is not cycled on and or off too rapidly.

## Defrost Cycle

Independent of the temperature, the relay, therefore the compressor, will be turned off for a defrost cycle after 120 minutes of compressor run time. The defrost cycle will last a minimum of five minutes or until the temperature of the cabinet exceeds 45°F (5.5°C). The power for the evaporator fan motor is constant and continues to operate during a defrost cycle.

## Settable Temperature Range

The temperature for this machine when dispensing perishable food is set automatically to 36°F when "Food" is chosen as the machine type. When selling non-perishable products and the machine type is set to "Zone", the settable temperature range is from 37°F to 80°F (3°C to 27°C). The recommended temperature when the machine is equipped with bottle shelves is 42°F (5.5°C). When using the machine to dispense typical candy and confectionary products, the recommended temperature is 65°F (18°C).

## Setting the Temperature

Refer to Service Mode 40 for the procedure to set the temperature.

## Checking the Current Temperature

The temperature inside the machine can be viewed from the outside by pressing and holding the \* key for degrees °F or # key for degrees °C.

## Refrigeration Driver Board (RDB)

The Refrigeration Driver Board (P/N 80492751) is located inside the power supply box. The RDB has the capability to maintain two temperatures, however in this design, only the lower zone is monitored. Power and communication to operate the RDB is supplied via the MDB connector on the logic board using a communications cable. Power to operate the refrigeration unit is supplied to the Refrigeration Driver Board immediately after the EMI filter and is switched on and off by a relay on the Refrigeration Driver Board.

## Temperature Probe

The temperature probe (P/N 13600001-01) is located in the cabinet below the bottom shelf on the right hand side, just below the evaporator coil. The probe is connected to JP3 on the RDB. An unplugged or open temperature sensor probe will display as -9°F (-9°C). A shorted probe will display as 99°F (37°C).

For complete pin-outs of the Refrigeration Driver Board, see the Troubleshooting Section of this manual.

## Health Control Check

Use this procedure to verify proper health control operation.

1. Setup temperature. Note: Changing the setting in Mode 40 to food will insure this is done correctly.
2. Turn on Health Shutdown in Mode 42, be sure to set all selections in the machine to on by pressing 1\*\* in the selection field.
3. Unplug the door switch from P2 of the logic board to simulate door closure.
4. Close the door and allow the temperature in the machine to stabilize. If the machine was at temperature this will take a minute or less.
5. Once temperature has stabilized, open the door and power down the machine. Note: the evaporator fan will continue to run.
6. Leave the door open and let the machine warm up for 6 minutes. Note: Do not leave the machine powered down for more than 10 minutes.
7. Power the machine back up and within 3 minutes the machine should go into health shutdown. The display should now show "Selection 1XX Out of Service".
8. Reset the temperature setting in Mode 40, if it was changed in step 1.
9. Reset the Health Shutdown settings in Mode 42, if they were changed in step 2.
10. Plug in the door switch and clear the error.

# Hosting

The Fusion Machine may be used to host a 137/937 MultiMate machine. The following steps should be followed.

## 137/937 Instructions

1. Check the software version of the MultiMate driver board. For the MultiMate to work properly with a Fusion machine the driver board software must have Revision 9 or greater. Arrow A in the diagram below.
2. Set the cabinet jumper to cabinet 2. Jumper B in diagram below.
3. Plug the communications cable directly into the MDB plug on the Fusion control board.
4. Set the PosiVend selection in Mode 21 if applicable.
5. Set prices in Mode 20.

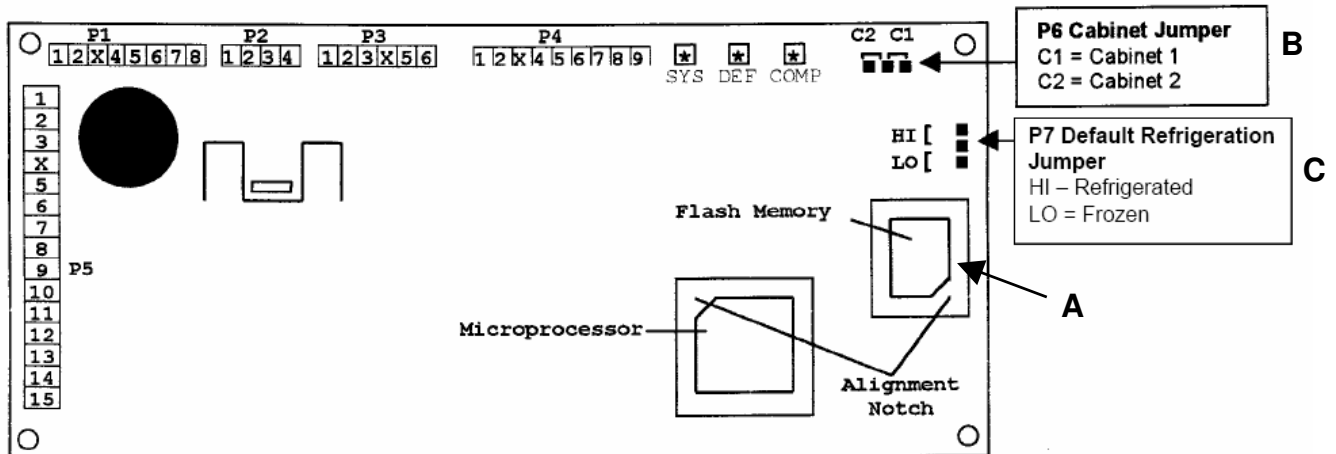

# Components

## Power Supply

The 120 VAC power cord from the wall outlet enters the machine and plugs into the bottom of the main junction box located on right side of the cabinet. The junction box contains the power distribution components, consisting of the control board, filter, circuit breakers and the transformer. The voltage outputs from the junction box to the board are 24 volts and 8 volts and plugs into the (P3 position) of the Logic Board.

## Lighting System

The Fusion machine features a new low voltage LED color corrected lighting system. This system consists of a 9.4VDC regulating power supply and 12 – 1 Watt LED's producing 60 lumens of light.

## Flexi Shelves

The Fusion machine features the new Flexi Shelf. With the new Flexi Shelf all of the selection dividers are removable allowing the shelf to be configured to vend wide products such as submarine type sandwiches. There are either five or six main product shelves per machine. Each selection has its own motor mounted to the back of the shelf. Every shelf has its own harness and plug for connecting to the remainder of the circuit through the cabinet receptacle, located in the rear right of the cabinet. It is possible to exchange a five selection shelf with a ten selection shelf or visa versa. The tracks in the back of the cabinet permit the vertical movement of the shelves in one inch intervals. To do this the shelf should be removed and the cabinet back harness receptacle lowered or raised along with the right & left shelf tracks.

## Note

- ◆ When exchanging the shelves, you will not need any parts but you will have to reprogram the machines prices.

## Pairable Motor Shelf

The Fusion models permit the pairing of two sequential motors on a shelf. This feature allows 2 candy selections to be converted to a dual spiral snack selection, by removing the product divider between the spirals, and pairing the motors electronically. See Mode 23 for additional information on pairing motors.

## Bottle Shelf

The Fusion model includes up to 3 – 8 select bottle shelves. The bottle shelves can be raised or lowered to vend up to 24 ounce bottles.

## Delivery Bin

This is located below the display window on the door and is mechanically operated.

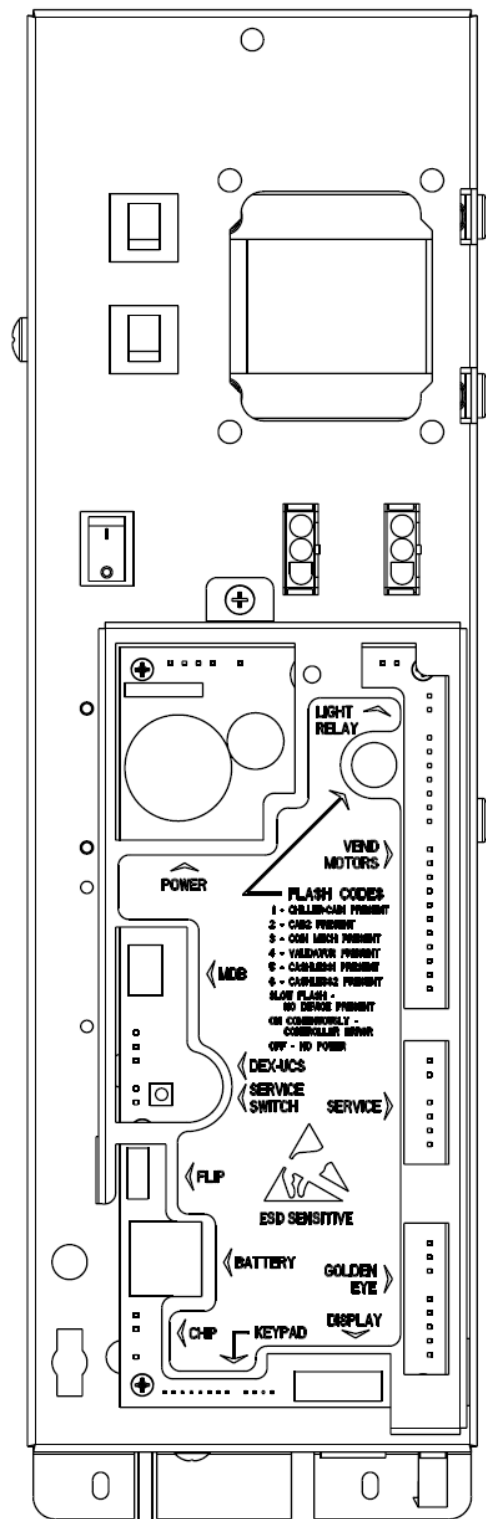

Figure 11: Power Supply Box.

# Components

## Vend Motors

The vend motors used in the Fusion machines have been specifically developed to operate with the GPL Control System. One primary difference that distinguishes the new motors from previous motors is the presence of an eight sided star at the drive hub of the motor. This permits the stopping position of the spiral to be customized by the operator to ensure the best possible delivery of product. Motors are of the fast trac style, with all electronics required to correctly operate the motor contained inside the gear case or the motor housing and no external control board. Each of the motors used with the Fusion Control System will have two terminals. The two terminals continue to be used to identify the shelf and column (selection) to be vended.

Each motor requires two wires to operate correctly. These wires are: shelf common, and selection.

Each selection on a shelf will have the same common shelf wire - all shelf harness use wire #12 as a shelf common. This corresponds to the selected shelf wire in the cabinet harness. The terminal for the shelf common in the harness is the smaller of the two.

Selection numbers are assigned from left to right, starting with selection 0. Each selections number corresponds to the number of the wire for that selection.

Selection numbers in the Fusion Machines support a three digit selection system. The first digit indicates the cabinet number, the second digit is the shelf number and the third digit is the selection number on that shelf.

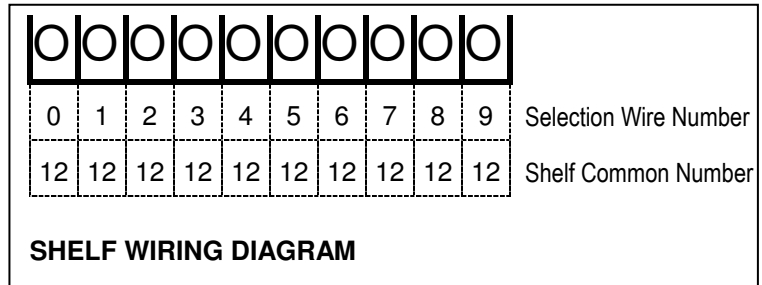

Part #	Case Color code	Description
<b>360275</b>	1/2 blue, 1/2 white, 8 point star drive	<b>CW food/Snack motor</b>
<b>360276</b>	1/2 blue, 1/2 grey, 8 point star drive	<b>CCW Food/Snack motor</b>
360240	1/2 blued, 1/2 white, 8 point star drive	Dual spiral
360241	1/2 white, 1/2 brown, 8 point star drive	1/2 cycle motor

### Fusion Motors.

**Motors highlighted in bold are standard production motors. All other motors are available through aftermarket parts only.**

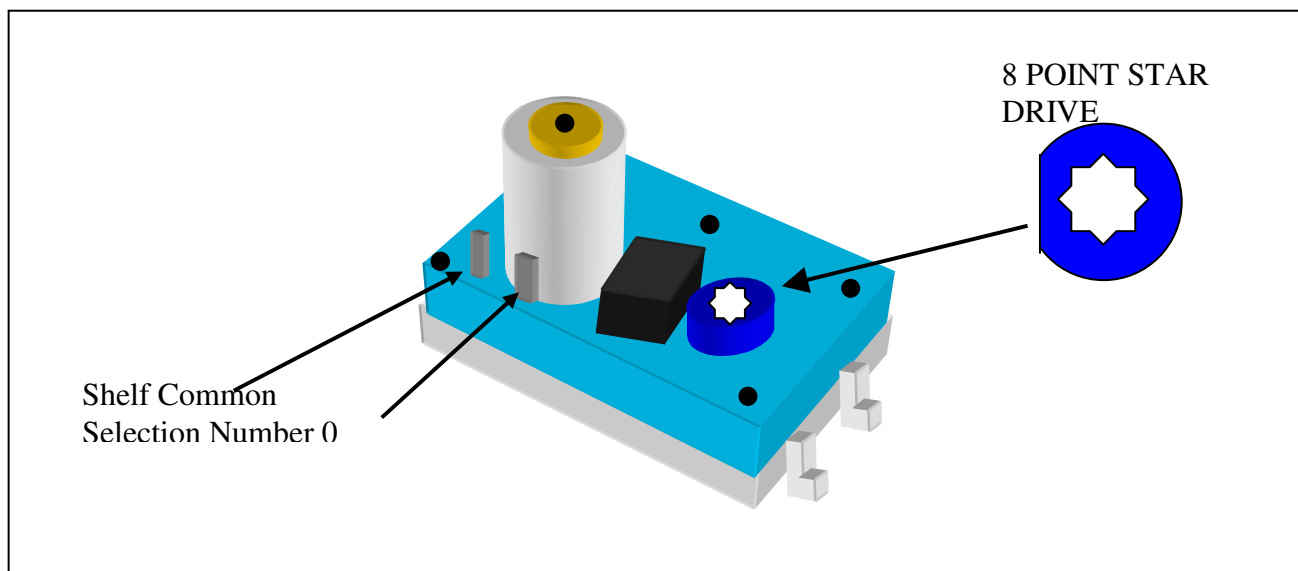

# Components

## Logic Board & Display

The control board contains all of the decision-making and display controls. All peripherals plug into the controller. The all new Fusion display contains 2 display lines each with a maximum of 20 characters. All Credit, Price, Diagnostic Information and Options (In Service Mode) will be displayed on this display.

A new feature added to the Fusion Machines is a real time clock. This addition will allow the programming of timed events such as discounts and shutdowns (see the programming guide in this manual for more details).

## Keypad

The Selection keypad is located on the door directly below the display. The Selection Keypad is used as an input source for settable data while in the Service Mode. The keypad is only active for service functions when the door is open, so even in the event of vandalism to the control bezel; no access to the control functions is permitted.

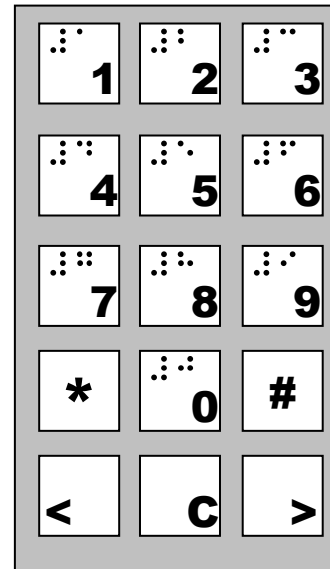

Fusion keypad.

## Coin Mechs, Validators and Card Readers

The Fusion Machines support MDB protocol only. The maximum number of MDB payment peripherals is one coin mechanism, one bill validator, and two card reader systems.

The Fusion will automatically determine at power up which peripherals are connected and configure itself accordingly.

	MDB Coin Mechanism	MDB Bill Validator
<b>Mars</b>	TRC-6510 TRC-6512 VN-4510 CF7512	VN2502-U5M VN2602-U5M
<b>CoinCo</b>	9302-GX, USQ-G701 USQ-G703 USQ-L701	BA32R BA52R MAG32 MAG52
<b>Conlux</b>	USLZ-004-01F CCM 5 G	USLZ-004-01F

◆ **Contact your coin mechanism and validator supplier for additional models.**

## GPL PosiVend™ Guaranteed Delivery System

Modes of Operation for the Fusion

### Introduction

The premise behind the development and introduction of PosiVend (PV) was to improve customer (machine user) satisfaction by guaranteeing delivery of the product they have selected. In addition to increasing customer satisfaction and loyalty, the guaranteed delivery of products reduces operational costs and increases efficiencies, therefore making the operator more profitable.

An average service call costs between \$65 and \$100. PosiVend reduces these costly calls for product hang-ups and missed vends. PosiVend also eliminates the time and costs associated with credit vouchers due to missed vends. Lastly, operators may risk losing an account if product vend failure occurs on a repeated basis.

While careful and consistent loading of products helps to ensure a positive vend, PosiVend provides a positive vend solution that takes these variables out of the equation, and works efficiently and effectively to deliver the product.

### Function

The GPL PosiVend Guaranteed Delivery System consists of a series of 12 infrared pulsed beams that create a web of interlaced beams just above the opening of the delivery bin in our glass front machines. When any one of these infrared beams is broken by a product falling into the delivery bin during a vend, the PV sensors transmit a signal to the Logic Control Board that the vend occurred successfully, and payment is collected, and change is returned, if required. If the product is not delivered successfully, the credit reappears on the display and allows the customer to choose an alternate item, or press the coin return to receive their money back.

### Modes of operation

The PV system has three selectable modes of operation: **Off**, **Home**, or **Drop**. The operator has the option to choose any of these four modes, and once a mode of operation is selected, choose which selections in the machine will be monitored by PV.

#### Off Mode

When PV is set to **Off**, the PV system is disabled, and all selections in the machine will run one time only.

#### Home Mode

When PV is set to **Home**, and the customer makes their selection, the selection motor begins its cycle,

and the PV sensor begins watching for a product to fall into the bin. The selection motor makes a complete revolution, returns to the home position, and pauses for 2 seconds. If no product is detected, **the selection motor then runs a second complete cycle** attempting to deliver the product. The motor pauses a second time, and if no product was detected during this vend, the motor runs a third complete cycle. If a product is delivered during any of the three cycles, the purchase is completed, and any change required is returned. If no product was delivered during any of the three cycles, an error is created (see PosiVend Errors below). The credit reappears on the display and allows the customer to choose an alternate item, or press the coin return to receive their money back.

#### Drop Mode

When PV is set to **Drop** and the customer makes their selection, the selection motor begins its cycle, while PV sensor begins watching for a product to fall into the bin. The selection motor makes a complete revolution, returns to the home position, and pauses for 2 seconds. If no product is detected, the selection motor begins a second cycle, and if a product interrupts the sensor beams, **the selection motor stops immediately**, leaving the motor in an off home position. If no product is detected during the second cycle, the motor runs a third cycle, and stops immediately upon detection of the product dropping in the bin. If the motor is stopped in an "off home", position, the next time this item is vended, the motor returns to home and pauses. If a product is detected during this partial cycle, the motor remains at home, and the transaction is complete. If no product is detected, the motor begins a second cycle, and if a product falling into the bin is detected, the motor stops immediately, and the transaction is complete. If no product was delivered during any of the three cycles, an error is created (see PosiVend Errors below). The credit reappears on the display and allows the customer to choose an alternate item, or press the coin return to receive their money back.

#### PosiVend Errors

One of the critical new features of PosiVend is an increase in the number and type of diagnostic errors available to the technician to assist them in determining the cause of a PV error. The table below explains each of these available errors. More detailed information on these errors is available in the Troubleshooting section of this manual.

## POSIVEND XXX FAILED

After any selection motor (XXX) runs three times without PV detecting a product, an error is posted, and that selection is disabled from vending. If three different selections are disabled with PV errors, then a PV Disabled error is posted, and PV for the entire machine is disabled, and all selections operate as if PV was set to **Off**. For machines set to **Home**, this disabled condition remains until the machine door is opened and closed. For machines set to **Drop** the “C” key on the keypad be pressed before closing the door to return disabled selections to operation. The errors will remain until they are cleared.

GOLDENEYE XXX FAILED	Three items missed by the PosiVend Sensor. XXX indicates which selection.
CABx GOLDENEYE ERROR	Three different selections in a cabinet missed by the PosiVend Sensor. X indicates which cabinet
CABx TRAN + REC BAD	All Transmitters and Receivers bad - X indicates which cabinet.
CABx RECEIVER Y BAD	Receiver (Sensor) Y failed, Y indicates the number of the Sensor, X indicates which cabinet
CABx TRANSMTR Y BAD	Transmitter (LED) Y failed, Y indicates the number of the LED, X indicates which cabinet
CABx TRN Y TO REC Y	Transmitters Y not seen by Receiver Y, X indicates which cabinet

### Choosing Between Drop vs. Home

Please consider the information below when deciding which mode of PosiVend to use:

1) If a machine is set to the **Drop** mode, the “automatic motor scan upon door closure to restore all the motors to their home position” is disabled. To perform a motor scan and cycle all motors to their home position, **you must first press the “C” key on the Key Pad before closing the door.** This trademark feature of GPL equipment since 1985 is a valuable diagnostic tool and it will also warn a route service person if they have not pushed all the shelves back into their normal position after servicing.

Utilizing the drop mode disables the automatic function of this important feature. Route service personnel should be instructed to press Mode Switch and the door switch to home all the motors before filling the machine.

**2) If a machine is set to the Drop mode, and a route service person ignores the errors stored, and closes the door without pressing the “C”**

**key, they will leave the previously disabled selection still disabled, even though they may have cleared any product jams or misloads, and refilled the selection.**

3) The **Drop** mode may leave some selections in an “off home” spiral position. Historically, GPL snack machine spirals self-home, so it is possible that route service personnel and/or consumers may question a selection’s off home spiral appearance. Consumers may avoid that selection, or the machine altogether, thinking that something is “wrong” with it. This may lead to an unnecessary service call. When using the either of the **Drop** modes you may want to reassure your client that spirals in an “off home” position are normal and will produce a positive vend

4) The **Home** mode keeps the “motor scan upon door closure to restore all the motors to their home position” automatically enabled.

5) The **Home** mode will always leave selections in their home spiral position.

6) PosiVend *could* deliver a second product on a failed vend. However, the extra occasional product cost is well worth the savings of a service call due to a product hang-up or missed vend.



## PosiVend® sensor coverage looking down into the delivery bin.

Front of Machine - Glass

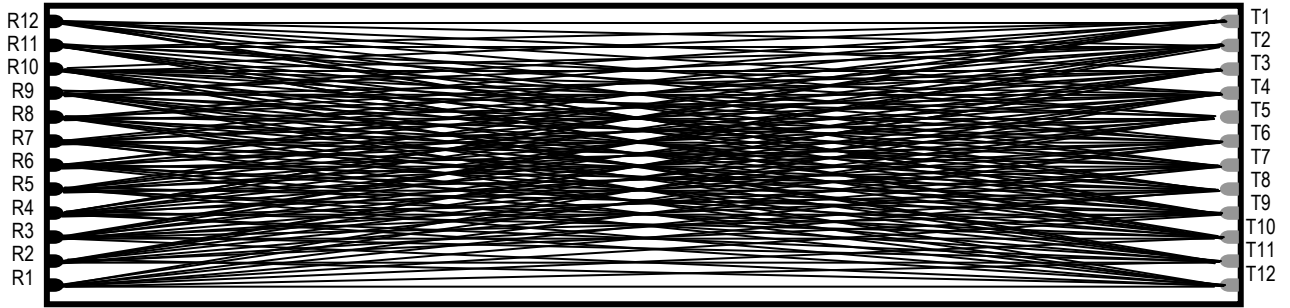

Inside of Machine

Fusion Delivery Bin – drawn to scale



For scale, circle at left represents  
a US dime and quarter.

Rxx = Receiver number

Txx = Transmitter number

# Operating System

## Power Up State

Following a power-up or reset condition, the display will show "AUTOMATIC PRODUCTS" on the top line and "GPL / CMS" with three bouncing dots on either side on the bottom line.

## Motor Scan

Upon closing the door the display will show the firmware revision level (see Figure 11), perform a diagnostic routine that will scan and home the motors determining what motors exist in the configuration. After completion of this scan, the status of all the motors will be reported on the display (see Figure 12).

## Standby

In Standby, the operator selected message will appear on both the top and bottom line. The factory default messages are "Have a nice day" on the top line, and "Credit .00" on the second line. See the Operating system, Mode 60 for details on how to change the standby message. As soon as credit is deposited, the accumulated credit will be shown on the bottom line until a selection is made.

## Keypad echo

When the first numeric key is pressed the display will show the selection number in the third leftmost digit. This character will remain for 5 seconds or until another key is pressed. Once all 3 keys are pressed, the selection will be shown on the display for one second and then the associated price for the product will display. If the selection is disabled or shut down (using the Shutdown pins) the display will show "Invalid selection" for 5 seconds or until a new selection key is pressed. If the selection is enabled but not functioning properly (not present or not home) the display will show "Make Another Selection" for 5 seconds or until a new selection key is pressed.

## Credit Accumulation

Credit may be accumulated through a coin changer, bill acceptor or card reader. A non-revaluing card reader credit cannot be mixed with coin and/or bill credit during a single transaction or vend. If card reader revalues the coin & bill credit goes to the card, and then a vend may still be attempted. Credit acceptance will be disabled when the accumulated credit equals or exceeds the highest priced item. Credit accumulation from any source is disabled or escrowed if change is not available. If the amount of card reader credit available exceeds the maximum displayable credit, the maximum credit will be displayed.

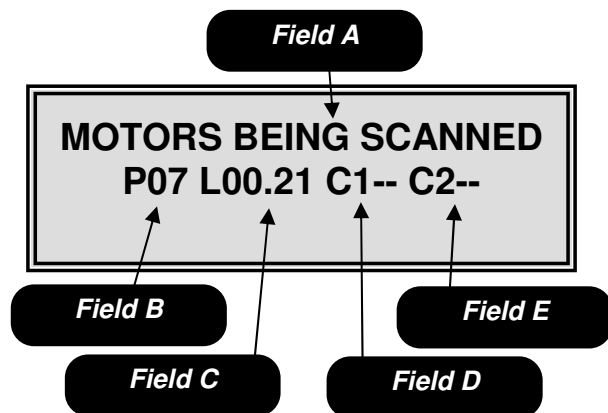

FIGURE 11

**Field A** is the informational heading.  
**Field B** is the microprocessor version number.  
**Field C** is the software version number.  
**Field D** is the software version in the temperature control board for cabinet 1.  
**Field E** is the software version in the temperature control board for cabinet 2.

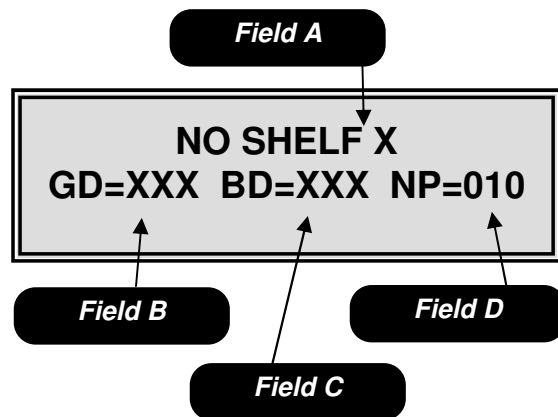

FIGURE 12

**Field A** shows the lowest shelf number not found during the automatic scan of motors.  
**Field B** is the number of good motors.  
**Field C** is the number of bad motors.  
**Field D** is the number of motors not present.

# Operating System

## Vend Process

After a keypad entry is made the logic board determines if sufficient credit is available for the selection attempted. If the credit is greater than or equal to the selection price, a vend attempt will be made for that selection. During this time, the selection will be shown on the display. If credit is less than the selection price, the correct price and current credit amount will be displayed for 5 seconds or until a new selection key is pressed.

## Change Payment

Change will be returned during the vend process as soon as it is determined that the motor has moved off of the home position. This will change if PosiVend is active. When PosiVend is active, the transaction is not completed until the PV sensors confirm delivery of the product. The amount of change to be returned will be displayed until all coinage is paid back. The least amount of coins available will be paid back for all credit returns.

## Use Correct Change

If the level of the changer's least value coin tube is below the lowest sensor, the "Use Correct Change" message will be shown on the display. If the machine is unable to vend the selected item because of low change, the display will show "Use Correct Change" for 5 seconds or until a new selection key is pressed.

## Make Another Selection

If the machine is unable to vend the selected item, the "Make Another Selection " message will be displayed for 5 seconds or until a new selection key is pressed.

## Token Vends

Following the acceptance of a token, the display will show "FREE". Further credit acceptance is disabled and a single item may be selected to vend for the token credit. See the Operating Section Mode 29, for instructions on setting up and choosing which selections will work with tokens.

## Accountability Information

All MIS data is stored as both resettable and non-resettable with the exception of Machine Identification Number, Machine Serial Number, Software Version Number, Number of MIS Resets, Number of Machine Resets and Door Open History, which are stored as non-resettable only. All vend counters will roll over at 7 digits (9,999,999). All cash counters will roll over at 8 digits including the decimal point (999,999.99). Vend accounting (MIS) is updated as shown in Table 1.

Field	Vend Type			
	Token	Vend	Testvend	Freevend
#VENDS	X	X		
\$VENDS (Sale Price)	0	X		
#/PROD	X	X		
\$/PROD (Sale Price)	0	X		
#/TESTVEND			X	
# /FREE				X
\$ /FREE				X
# /TOKEN	X			
\$ /TOKEN	X			

**Table 1: MIS Field Update Chart**

X - Indicates which field is updated for a given vend type.

## Shutdowns

There are 2 options available to shutdown the Fusion machine.

1. The Fusion machine is capable of having timed shut down periods. More information can be found in the programming section Mode 51.

2. The control board on the Fusion machine can be shutdown by creating a closed circuit between pin 3 & pin 4 on the service connector P2. This shutdown type will lock out selections entered into mode 32. When in this shutdown type and a shutdown selection is entered the display will show "Invalid Selection" for 5 seconds or until a new selection key is pressed.



**Caution: Do not apply Voltage to these pins! Damage to the Board will result!**

## DEX/UCS

The Fusion supports DEX/UCS Communications Protocol - NAMA Vending Industry Data Retrieval Standard. The machine will automatically recognize the DEX/UCS device when it is plugged into the control board and will recognize when the device initiates the communication protocol. The transmission/reception of data to the device will then take place automatically. See the next page of this manual for definitions of the DEX/UCS download protocol.

◆ See Page 5.31 for information regarding the setting of a Serial Number, Machine ID and Location ID.

# Operating System

The MIS data stored by the machine for a DEX/UCS download is as follows:

DEX/UCS Output	Definition
ID1*API74563219087456123*STXX*0010*98765432198765432**12345678901234567	Machine S/N*Machine Model*Machine Revision*Location ID**Machine ID #
ID4*2*1*0	# of positions to right of decimal pt*Country (ITCC)*Currency in use
ID5*050510*122708	System Date -YYMMDD*Time - HHMM
ID7***APi	***Manufacturer Code
CB1*API33221144556699887*ST/130*0001 VA1*1200*18*300*5*0*18*0*5	Control Board Serial Number*Model*Software revision Total Sales Historical Amount*Total Vends Historical Count*Total Interval Sale Amount*Total Interval Vends*Historical Value of All Discounted Paid Vends*Historical count of All Discounted Paid Vends*Interval Value of All Discounted Paid Vends*Interval Count of All Discounted Paid Vends
VA2*0*2*0*0	Historic Value Test Vends*Historic Test Vends*Interval Value Test Vends*Interval Test Vends
VA3*0*0*0*0	Value -Free Vends Historical*Count -Free Vends Historical*Value -Free Vends Interval*Count -Free Vends Interval
TA2*0*0*0*0	Value -Token Vends Historical*Count -Token Vends Historical*Value -Token Vends Interval*Count -Token Vends Interval
CA1*0*0*0	Serial Number*Model*Software revision
CA2*1200*18*300*5	Total Cash Historical*Total Cash Vends Historical*Interval Cash*Interval Vends
CA3*350*0*150*2*1350*0*850*5*200*500	Interval cash received*Interval Cash to Cashbox*Interval Cash to tubes*Interval Value of Bills*Historical Cash received*Historical Cash to Cashbox*Historical Cash to Tubes*Historical Value of Bills*Interval Value of Bills
CA4*50*0*1150*1100	Interval cash dispensed*Interval cash dispensed manually*Historical cash dispensed*Historical cash dispensed manually
CA7*0*0*5*18	Interval Value cash discounts given*Historical Value cash discounts given*Interval Number cash discounts given*Historic Number cash discounts given
CA9*0*0	Value of Vends while in exact change-interval*Value of Vends while in exact change-historical
CA10*0*0	Value of all cash added since last reset*Value of all cash added since initialization
CA15*1225	Value of coin tubes
BA1*29821563422*SPRINTR*504	Bill Validator Serial Number*Model*Software revision
DA1*0*0*0	Cashless 1 Serial Number*Model*Software revision
DA2*0*0*0*0	Cashless 1 Historical Vends*Historical Cash*Interval Vends*Interval Cash
DA4*0*0	Historical Value credited to Cashless 1*Interval Value credited to Cashless 1
PA1*CAN	Can Sales Header
PA2*4294919762*550	Historical Vends-Cans*Historical Cash-Cans
<b>PA1*110*50*110*0 (See Note 1)</b>	Selection ID*Vend price*Product code*Spiral Count
<b>PA2*0*0*0*0 (See Note 1)</b>	Historical Vends Selection 110*Historical Cash Selection 110*Interval Vends Selection 110*Interval Sales Selection 110
<b>PA4*0 (See Note 1)</b>	Historical Free Vends Selection 010
<b>PA5*050510*122708 (See Note 1)</b>	Date & Time of last vend for this selection
EA1*EGS*000000*000008*00	EGS(Door Opening History)*Date YYMMDD*Time HHMM*Duration (minutes)
EA2*EGS*1*4**1	EGS*Interval Door Openings*Historical Door Openings*Current Status 1 = Door open
EA1*EJB*000000*000008*00	EJB (Motor Errors)*Date YYMMDD*Time HHMM*Duration (minutes)
EA2*EJB*60*194**1	EJB*Interval Motor Errors*Historical Motor Errors**Current Status 1 = Motor Error exists
EA1*ELA*000000*000008*00	ELA (Product Delivery Errors)*Date YYMMDD*Time HHMM*Duration (minutes)
EA2*ELA*0*0**0	ELA*Interval Product Delivery Errors*Historical Product Delivery Errors**Current Status 1 = Detector OK
EA1*EJH*000000*000008*00	EJH (Health Code Errors)*DateYYMMDD*Time HHMM**Duration (minutes)
EA2*EJH*0*0	EJH*Interval Health Code Errors*Historical Health Code Errors**Current Status 1 = Detector OK
EA1*OA1E*000000*000008*00	OA1E (Date & Time Resets)*Date YYMMDD*Time HHMM**Duration (minutes)
EA2*OA1E*0*0	OA1E*Interval Date & Time Resets*Historical Date & Time Resets**Current Status Always = 0
EA3*2*****2*2	Number Of Reads With Reset Since Initialization*****Number Of Reads Since Initialization*Number of Resets since Initialization
EA4*000000*000008	(Initialization Timestamp)YYMMDD*Hums
EA5*000000*000008	(Price Setting Timestamp)YYMMDD*Hums
EA7*0*2	Power up/down cycles since last reset*Power up/down cycles since initialization

# Operating System

---

<b>DEX/UCS Output</b>	<b>Definition</b>
CA304	Value of Bills In Since Last Reset - all sources
CA305	Value of Cash In Since Initialization - all sources
CA308	Value of Bills In Since Initialization - all sources
CA310	Value of Bills In Since Initialization - all sources
CA403	Value of Cash Dispensed Since Initialization
CA404	Value of Cash Manually Dispensed Since Initialization
CA1501	Value of Tube Contents
MA5508	Value of Bills to Stacker Since Initialization
MA5510	Value of Bills to Recycler Since Initialization
MA5603	Value of All Coins Dispensed Since Initialization
MA5606	Value of All Bills Dispensed or Moved from the Recycler Since Initialization
MA5608	Value of All Bills Dispensed Manually from the Recycler Since Initialization
MA5610	Value of All Bills Manually Stacked from the Recycler Since Initialization
MA5701	Value of Coins in Coin Tubes
MA5702	Value of Bills in Recycler
MA5802	Value of Bills to Recycler in Manual FILL Mode Since Initialization

Note: PA1, PA2, PA4 and PA5 Fields repeat for each valid selection.

**Table 2: DEX/UCS Information.**

# Programming

## Service Modes

The table on the right side of this page is a copy of the decal found on the left side of the barrier inside the Ultra Flex machines. This decal provides a list of the service modes described in the following pages.

Access to the Service Mode, is granted upon opening of the main door. If a period of no activity occurs for 5 minutes, the controller will automatically revert to the Operate Mode. Entrance to the Service Mode clears any current credit. If no errors are present the following display will appear (Figure 13).



**FIGURE 13: Initial Service Mode Screen when no errors are present.**

To enter the Service Modes (see Figure 15) press the C key or use the numeric key pad to enter the Service Mode number.

If errors are present the error reporting screen will be displayed (see Figure 14). Use the ◀ and ▶ keys to scroll through the errors listed. Press the # key followed by the \* key to clear the errors. To enter the Service Modes (see Figure 15) press the C key or use the numeric key pad to enter to the Service Mode number.

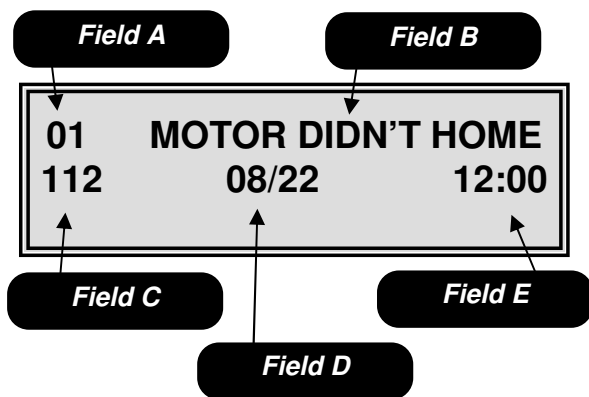

**FIGURE 14: Initial Service Mode Screen when errors are present.**

**Field A** is the sequential number of the error.

**Field B** is the error description field.

**Field C** is the motor number if applicable.

**Field D** is the date of the error.

**Field E** is the time of the error.

◆ See the Troubleshooting Section of this manual for specific information regarding the errors being reported.

◆ To coin test the machine with the door open either press the Service Switch (see Figure 16) or unplug the door switch from the control board.

LOGIC BOARD FLASH CODES	
LED Status	Meaning
On Steady	Controller is not functioning
Off	Power to LCB is off
1 slow flash	No devices are attached to MDB port, but the controller is working
1 flash	LCB has detected a chiller unit in main cabinet
2 flashes	LCB has detected a second cabinet (À LA CARTE)
3 flashes	LCB has detected an MDB coin mech
4 flashes	LCB has detected an MDB bill validator
5 flashes	LCB has detected an MDB cashless payment system

SERVICE MODES	
ACCOUNTABILITY	
01	Historical Accountability
02	Historical Sales By Selection
03	Interval Accountability
04	Interval Sales By Selection
05	Clear Interval Accountability
06	Print-out Accountability
MACHINE SETUP	
10	Tube Fill Mode
11	External Accountability
20	Price Assignment
21	Golden Eye Enable Setup.
22	Bill Escrow Setup
23	Motor Pairing
24	Winner Vend
25	Force Vend Setup
26	Multiple Vend Setup
27	Combo Vend
28	Free Vend Setup
29	Free Vend Coupon
30	Chip Load/Store
31	Setup Change Playback
32	Machine Lockout
33	Spiral Count
34	Speech / Chime Enable
35	Security
36	Space to Sales
37	Max Payout
REFRIGERATION SETUP	
40	Set Temperature
41	Set up Defrost
42	Health Shutdown By Selection
TIME FUNCTIONS	
50	Current Time
51	Timed Shutdown
52	Timed Discount
53	Timed Messages
MESSAGE SETUP	
60	User Messages
61	After Sale Message
62	Out Of Service Message
DIAGNOSTICS & SERVICE	
80	Test Vend
81	Sequential Event Log
82	Service Log
83	Temperature Log
84	Test Baffle Door

TO VIEW AND CLEAR ERRORS:	
If errors exist, they will be shown on the display upon entering the service mode or by pressing <b>C</b> to exit a service mode.	
Use ▶ or ◀ to scroll through the errors.	
Press # then * to clear errors.	

	<b>FOR ADDITIONAL INFORMATION ABOUT ANY OF THESE SERVICE MODES, REVIEW THE OPERATING SYSTEM SECTION OF THE SERVICE MANUAL!</b>
--	--

# Programming

Figure 15 shows the first screen encountered after pressing the C key in either of the previous two screens (Figure 13 and Figure 14). Use the ◀ or ▶ keys to scroll sequentially through the modes or use the numeric key pad to enter the Service Mode number.

Entering one of the Service Mode numbers shown on the following pages allows you to access that Service Mode. **Example: entering 20 will take you into the Price Assignment Mode.**

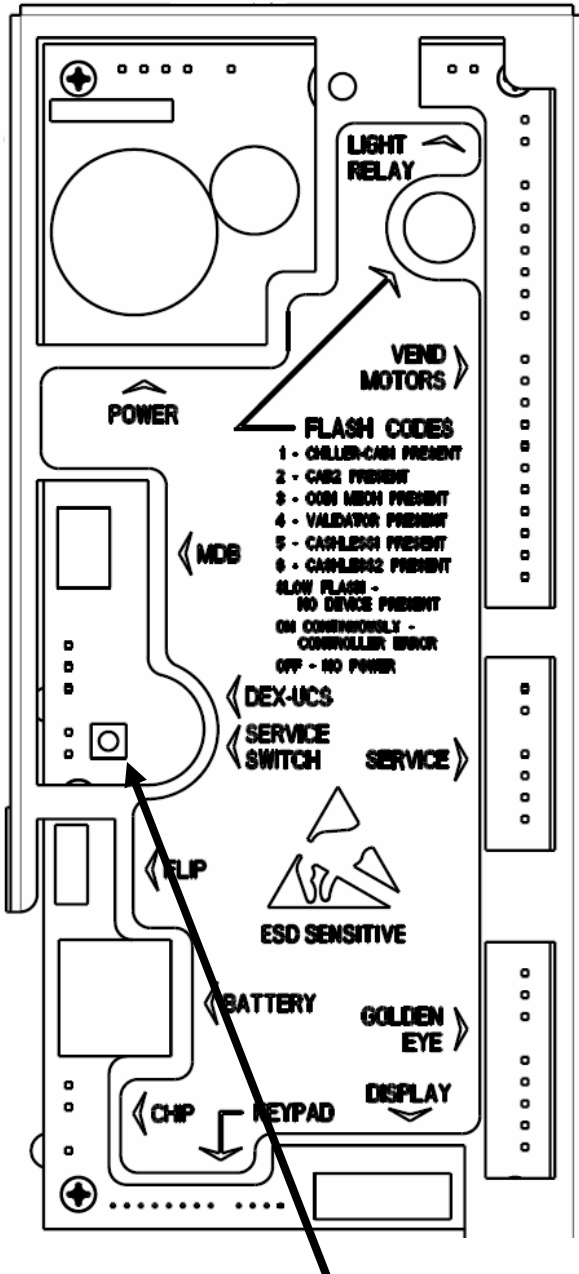

Figure 16: Location of Service Switch.

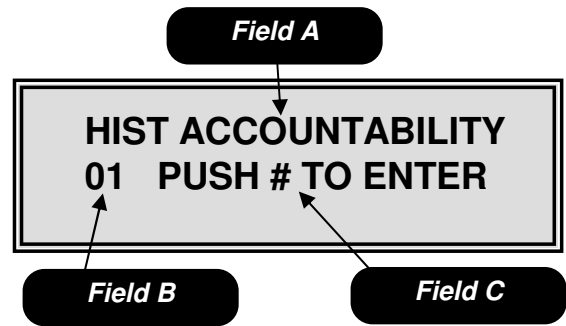

FIGURE 15: First Service Mode Number Screen.

*Field A* is the mode name.

*Field B* is the mode number.

*Field C* is the mode entering instructions.

Use the ◀ or ▶ keys to scroll sequentially through the mode numbers.

# Programming

## Mode 01 – Historical Accountability

Mode 01 is used to view the historical accountability. To access this mode, press **01** on the numeric keypad.

Pressing either the ◀ or ▶ key will sequence you through the historical accountability fields in the order shown in the table below. To exit this mode, press the **C** key or press the Service Switch.

FIELD A	DESCRIPTION
The display will show	
<b>HIST PAID SALES</b> #0000000 \$0000000.00	Total Value of Sales
<b>HIST NUMBER TESTS</b> #0000000	# of Test Vends
<b>HIST FREE VENDS</b> #0000000 \$0000000.00	Free Vends
<b>HIST CASH VENDS</b> #0000000 \$0000000.00	Cash Sale
<b>HIST VALUE BILLS</b> \$000000	Value of Bills Stacked
<b>HIST VALUE CASH</b> \$0000000.00	Value of Cash In
<b>HIST VALUE TUBE</b> \$0000000.00	Value of Coins to Tubes
<b>HIST VALUE BOX</b> \$0000000.00	Value of Coins Routed to Cash Box
<b>HIST VALUE DISP</b> \$0000000.00	Value of Cash Dispensed
<b>HIST VALUE MDISP</b> \$0000000.00	Value of Cash Manually Dispensed
<b>HIST VALUE ECV</b> \$0000000.00	Value of Exact Change Vends
<b>VALUE TUBE COINS</b> \$0000.00	Current Value of Coins in Tubes
<b>HIST TOKEN VENDS</b> #0000000 \$0000000.00	Token Vends
<b>HIST CASHLESS VENDS</b> #0000000 \$0000000.00	# of Cashless Vends
<b>HIST CAN VENDS</b> #0000000 \$0000000.00	Can Vends
<b>HIST CAB 1 VENDS</b> #0000000 \$0000000.00	Cab 1 Vends
<b>HIST CAB 2 VENDS</b> #0000000 \$0000000.00	Cab 2 Vends
<b>GOLDEN EYE REVISIONS</b> CAB1 00 CAB2 00	PosiVend Software Revision
<b>HIST NUMBER GE</b> #0000000	# OF PosiVend Spiral Turns

Table 4: Historical accountability fields.

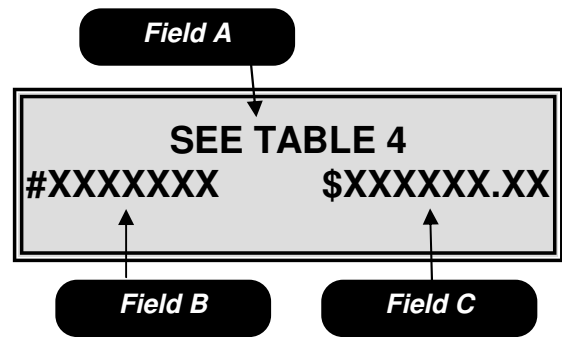

### Mode 01 – Historical Accountability

**Field A** is the accountability name field.

**Field B** is the total vend count field.

**Field C** is the total value field.

◆ When a data field begins with a # symbol this indicates a vend counter. When the data field begins with a \$ sign this indicates a cash value.



# Programming

## Mode 02 – Historical by Selection

Mode 02 is used to view the historical accountability by selection. To access this mode, press **02** on the numeric keypad.

Pressing either the ◀ or ▶ key will sequence you through the selections or use the numeric key pad to enter a selection number into Field A. Field B shows date and Field C shows you the time of the last vend for the selection shown in Field A. Field D shows you the number of vends and Field E shows you the total dollar value of vends for the item in Field A. To exit this mode, press the **C** key or press the Service Switch.

◆ **All time based information is dependent upon the clock on the control board being set correctly, see Mode 50.**

## Mode 03 – Interval Accountability

Mode 03 is used to view the interval accountability. To access this mode, press **03** on the numeric keypad.

Pressing either the ◀ or ▶ key will sequence you through the interval accountability fields in the order shown in the table below. To exit this mode, press the **C** key or press the Service Switch.

◆ **All interval data is reset to zero under the following two conditions.**

1. **A successful DEX download is performed, or**
2. **Mode 05 is used to clear the Interval data.**

**This also applies to the Interval data in Modes 04 and 06.**

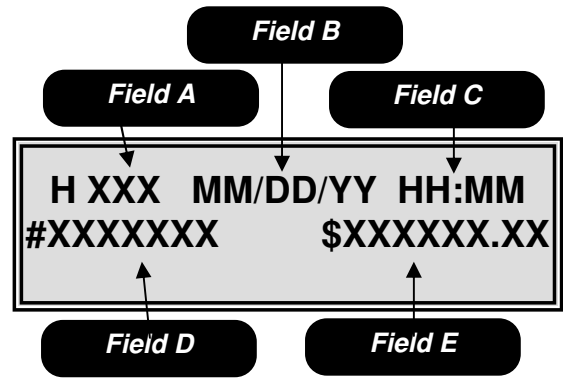

### **Mode 02 – Historical by Selection**

**Field A** is the item number.

**Field B** is the date of the last vend for the item in Field A.

**Field C** is the time of the last vend for the item in Field A.

**Field D** is the number of vends for the item in Field A

**Field E** is the historical dollar value of all vends for the item in Field A.

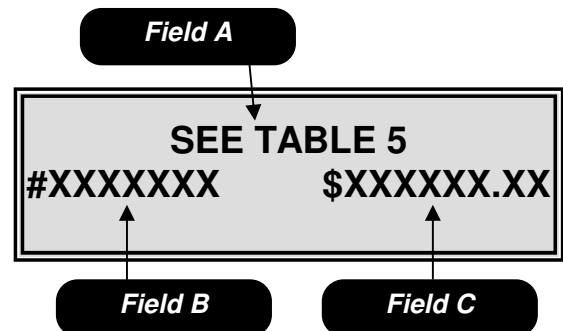

### **Mode 03 – Interval Accountability**

**Field A** is the accountability name field.

**Field B** is the interval vend count field.

**Field C** is the interval dollar value field.

# Programming

## Mode 04 – Interval by Selection

Mode 04 is used to view the interval accountability by selection. To access this mode, press **04** on the numeric keypad.

Pressing either the ◀ or ▶ key will sequence you through the selections or use the numeric key pad to enter a selection number into Field A. Field B shows date and Field C shows you the time of the last vend for the selection shown in Field A. Field D shows you the number of vends and Field E shows you the dollar value of vends for the item in Field A. To exit this mode, press the **C** key or press the Service Switch.

◆When the security option in Mode 35 is enabled only Modes 01 through 04 will be accessible without a password. Attempting to access any other Mode will prompt the operator to enter the correct password.

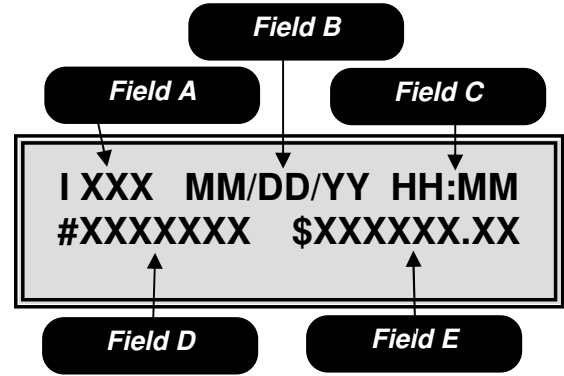

### Mode 04 – Interval by Selection

**Field A** is the item number.

**Field B** is the date of the last vend for the item in Field A.

**Field C** is the time of the last vend for the item in Field A.

**Field D** is the number of vends for the item in Field A

**Field E** is the dollar value of the vend for the item in Field A.

FIELD A	DESCRIPTION
The display will show	
<b>INTR PAID SALES</b> #0000000 \$0000000.00	Total Value of Sales
<b>INTR NUMBER TESTS</b> #0000000	# of Test Vends
<b>INTR FREE VENDS</b> #0000000 \$0000000.00	Free Vends
<b>INTR CASH VENDS</b> #0000000 \$0000000.00	Cash Sale
<b>INTR VALUE BILLS</b> \$000000	Value of Bills Stacked
<b>INTR VALUE CASH</b> \$0000000.00	Value of Cash In
<b>INTR VALUE TUBE</b> \$0000000.00	Value of Coins to Tubes
<b>INTR VALUE BOX</b> \$0000000.00	Value of Coins Routed to Cash Box
<b>INTR VALUE DISP</b> \$0000000.00	Value of Cash Dispensed
<b>INTR VALUE MDISP</b> \$0000000.00	Value of Cash Manually Dispensed
<b>INTR VALUE ECV</b> \$0000000.00	Value of Exact Change Vends
<b>VALUE TUBE COINS</b> \$0000.00	Current Value of Coins in Tubes
<b>INTR TOKEN VENDS</b> #0000000 \$0000000.00	Token Vends
<b>INTR CASHLESS VENDS</b> #0000000 \$0000000.00	# of Cashless Vends
<b>GOLDEN EYE REVISIONS</b> CAB1 00 CAB2 00	PosiVend Software Revision
<b>INTR NUMBER GE</b> #0000000	# OF PosiVend Spiral Turns

Table 5: Interval accountability fields.

# Programming

## Mode 05 – Clear Interval Data

Mode 05 is used to clear the interval data. To access this mode, press **05** on the numeric keypad.

Upon entering the display will show “CLEAR INTERVAL DATA”. Pressing the # key followed by the \* key will clear all interval data. To exit this mode without clearing the data, press the **C** key or press the Service Switch.

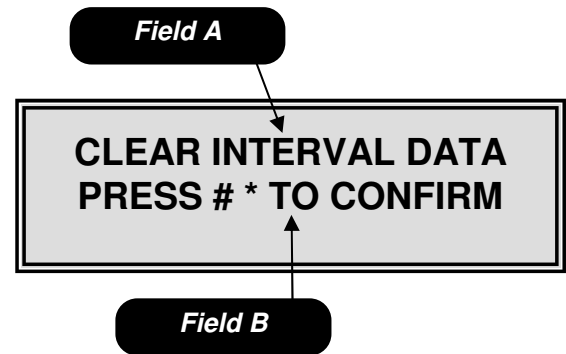

**Mode 05 – Clear Interval Data**  
**Field A** is the mode identification field.  
**Field B** is the instruction field.

## Mode 06 – Print out Accountability

Mode 06 is used to transmit the MIS information to a printer. To access this mode, press **06** on the numeric keypad.

Press the # key to send all historical and interval accountability including data by selection. Use the \* key to send all historical and interval data but not send the data by selection, for specific details of what is included in each list see Table 6. To exit this mode, press the **C** key or press the Service Switch.

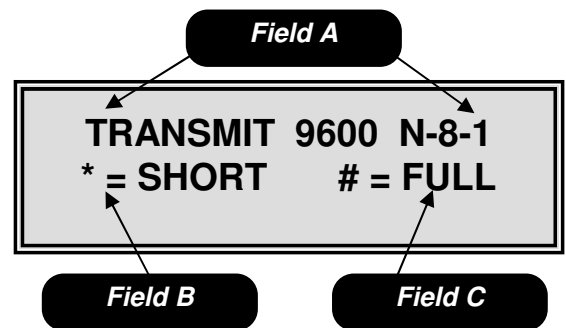

**Mode 06 – Print out Accountability.**  
**Field A** shows the transmission characteristics for the printer.  
**Field B** is the short list download instruction field.  
**Field C** is the full list download instruction field.

### Table 6 Notes

- ◆ An (H) at the end of the definition means historical data.
- ◆ An (I) at the end of the definition means Interval data.
- ◆ The column heading titled F is the full list.
- ◆ The column heading titled S is the short list.
- ◆ Fields highlighted in bold are repeated for each valid selection in the machine.

◆ See Page 5.31 for information regarding the setting of a Serial Number, Machine id and Location id.

# Programming

## Mode 06 - Continued

Field	Definition	F	S
ID101	Machine Serial #	X	X
ID102	Machine ID #	X	X
ID103	Machine Version #	X	X
ID104	Machine Location	X	X
ID106	Machine Asset #	X	X
ID501	System Date	X	X
ID502	System Time	X	X
ID703	Manufacturer Code	X	X
CB101	LCB Serial #	X	X
CB102	LCB ID #	X	X
CB103	LCB Software Version	X	X
ID401	Decimal Point Position	X	X
ID402	Country Code	X	X
ID403	Currency Code	X	X
VA101	Value of all Paid Sales (H)	X	X
VA102	Number of all Sales (H)	X	X
VA103	Value of all Paid Sales (I)	X	X
VA104	Number of all Sales (I)	X	X
VA105	Value of Discounted Sales (H)	X	X
VA106	Number of Discounted Sales (H)	X	X
VA107	Value of Discounted Sales (I)	X	X
VA108	Number of Discounted Sales (I)	X	X
VA201	Value of Test Vends (H)	X	X
VA202	Number of Test Vends (H)	X	X
VA203	Value of Test Vends (I)	X	X
VA204	Number of Test Vends (I)	X	X
VA301	Value of Free Vends (H)	X	X
VA302	Number of Free Vends (H)	X	X
VA303	Value of Free Vends (I)	X	X
VA304	Number of Free Vends (I)	X	X
BA101	Bill Validator Serial Number	X	X
BA102	Bill Validator ID Number	X	X
BA103	Bill Validator Software Version	X	X
CA101	Coin Changer Serial Number	X	X
CA102	Coin Changer ID Number	X	X
CA103	Coin Changer Software Version	X	X
CA201	Value of Cash Sales (H)	X	X
CA202	Number of Cash Sales (H)	X	X
CA203	Value of Cash Sales (I)	X	X
CA204	Number of Cash Sales (I)	X	X
CA308	Value of Bills Stacked (H)	X	X
CA304	Value of Bills Stacked (I)	X	X
CA305	Value of Cash in (H)	X	X
CA301	Value of Cash in (I)	X	X
CA307	Value of Coins to Tubes (H)	X	X
CA303	Value of Coins to Tubes (I)	X	X
CA306	Value of Cash to Cashbox (H)	X	X
CA302	Value of Cash to Cashbox (I)	X	X
CA3010	Value of Bills Stacked (H)	X	X
CA309	Value of Bills Stacked (I)	X	X
CA403	Value of Cash Dispensed (H)	X	X
CA401	Value of Cash Dispensed (I)	X	X
CA404	Value of Cash Manually Dispensed (H)	X	X

Field	Definition	F	S
CA402	Value of Cash Manually Dispensed (I)	X	X
CA702	Value of Cash Dispensed (H)	X	X
CA701	Value of Cash Dispensed (I)	X	X
CA704	Number of Cash Dispensed (H)	X	X
CA703	Number of Cash Dispensed (I)	X	X
CA902	Value of Exact Change Vends (H)	X	X
CA901	Value of Exact Change Vends (I)	X	X
CA1002	Tube Fill Value (H)	X	X
CA1001	Tube Fill Value (I)	X	X
CA1501	Current Value of Coins in Tubes (H)	X	X
MA501	Combo Vend Header	X	X
MA502	Value of Discount for Combo Vends (H)	X	X
MA504	Value of Discount for Combo Vends (I)	X	X
MA503	Number of Combo Vends (H)	X	X
MA505	Number of Combo Vends (I)	X	X
MA502	Value of Winner Vends (H)	X	X
MA504	Value of Winner Vends (I)	X	X
MA503	Number of Winner Vends (H)	X	X
MA505	Number of Winner Vends (I)	X	X
TA202	Number of Token Vends (H)	X	X
TA204	Number of Token Vends (I)	X	X
TA201	Value of Token Vends (H)	X	X
TA203	Value of Token Vends (I)	X	X
DA101	Cashless Serial Number	X	X
DA102	Cashless ID Number	X	X
DA103	Cashless Software Version Number	X	X
DA201	Value of Cashless Vends (H)	X	X
DA203	Value of Cashless Vends (I)	X	X
DA202	Number of Cashless Vends (H)	X	X
DA204	Number of Cashless Vends (I)	X	X
PA101	Can	X	X
PA202	Value of Can Vends (H)	X	X
PA201	Number of Can Vends (H)	X	X
<b>PA103</b>	<b>Selection Number Header</b>	<b>X</b>	<b>X</b>
<b>PA102</b>	<b>Price</b>	<b>X</b>	<b>X</b>
<b>PA107</b>	<b>Selection Status</b>	<b>X</b>	<b>X</b>
<b>PA202</b>	<b>Value of Vends by Selection (H)</b>	<b>X</b>	
<b>PA204</b>	<b>Value of Vends by Selection (I)</b>	<b>X</b>	
<b>PA201</b>	<b>Number of Vends by Selection (H)</b>	<b>X</b>	
<b>PA203</b>	<b>Number of Vends By Selection (I)</b>	<b>X</b>	
<b>PA401</b>	<b>Number of Free Vends by Selection (H)</b>	<b>X</b>	
<b>PA501</b>	<b>Time and Date of Last Vend (H)</b>	<b>X</b>	
<b>PA502</b>	<b>Time and Date of Last Vend (I)</b>	<b>X</b>	
LE101	Loop Trailer	X	X
EA301	Number of Reads with Reset	X	X
EA309	Number of Reads	X	X
EA3010	Number of MIS Resets	X	X
EA401	Date of Initialization	X	X
EA402	Time of Initialization	X	X

\* Items highlighted in bold repeat for each valid selection.

Table 6: MIS Definitions.

# Programming

## Mode 10 – Tube Fill

Mode 10 allows you to fill the coin mech and the logic board will count the money as it goes in and continually track the coin mech inventory. This is the count the board uses when you choose tube leveling as the payout type in Mode 31. To access this mode, press **10** on the numeric keypad.

Upon entering the tube fill mode the controller will display the current status of the coin tubes. As coins are inserted into the top of the changer, the display will show the tube the coin was saved to in **Field A**, the value of all coins in that tube in **Field B** and the total dollar amount of coins in the changer in **Field C**. Coins may be dispensed by using the switches on the coin mech. To exit this mode, press the **C** key or press the Service Switch.

◆ **Before using the machine for the first time, the coin mech must have a minimum of \$5 in the coin tubes to permit the acceptance of bills.**

## Mode 11 – External Accountability

Mode 11 is used to permit you or your customer, via a password, to review the total vend count and total cash accepted by the machine. To access this mode, press **11** on the numeric keypad.

Pressing either the ◀ or ▶ key will allow you to toggle back and forth between the fields.

Upon entering the external accountability setup mode, the display will show the current external accountability state. Use the numeric key pad to set a 4 digit security code in field A. Toggle to field B use the # key to turn the external accountability function on (Y) or off (N). To exit this mode, press the **C** key or press the Service Switch.

### Note

◆ If enabled, instruct the customer/contact to enter 8 and then the 4 digit code. The display will show the total vend count in **Field C** and the total value in **Field D**.

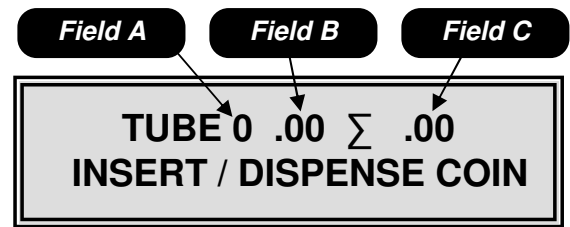

### **Mode 10 – Tube Fill**

**Field A** is the tube number the coin was saved to.

**Field B** is the value of coins in the tube identified in **Field A**.

**Field C** is the total value of coins in the changer.

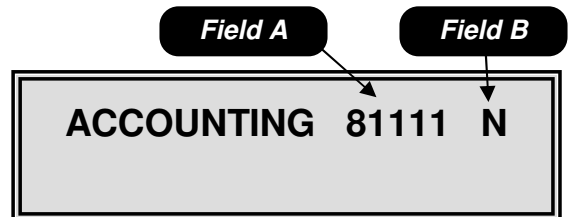

### **Mode 11 – External Accountability**

**Field A** is the security code field.

**Field B** is the feature on/off field.



### **Mode 11 – Customer Viewable Data**

**Field C** is the total vend count field.

**Field D** is the total value field.

# Programming

## Mode 20 – Price Assignment

Mode 20 is used to assign the standard price for all selections in the machine. To access this mode, press **20** on the numeric keypad.

Pressing either the ◀ or ▶ key will allow you to toggle back and forth between the fields.

Use the numeric keypad to enter the price in Field A, then toggle to Field B to assign the current price to a selection. To exit this mode, press the **C** key or press the Service Switch.

### Note

- ◆ The maximum price allowed is \$99.99.

### Special Actions

- ◆ Setting selections with a blank price disables that selection which means DEX information will no longer be transferred or displayed for items disabled in this way. The blank price is set by depressing the # Key.
- ◆ The \* key can be used as a wildcard in Field B to set entire rows (12\*) or the entire machine (1\*\*).
- ◆ After assigning the prices, make sure you adjust the scrolling price tabs to reflect the current or new price.

◆ You can use the ◀ or ▶ key while in the operate mode with the door open to check the prices in the machine.

## Mode 21 – PosiVend Enable Setup

Mode 21 is used to set up the PosiVend Guarantee Delivery System. To access this mode, press **21** on the numeric keypad.

Upon entering the PosiVend setup mode, the display will show the current PosiVend state in Field A. Toggle between the available options in Field A by using the # key. Each selection affected by the setting in Field A are shown in sequence in Field B, use the ◀ or ▶ key to scroll through these selections. Use the numeric keypad to add selections in Field B. To remove a selection from Field B, press the # key while the selection number is displayed. To exit this mode, press the **C** key or press the Service Switch.

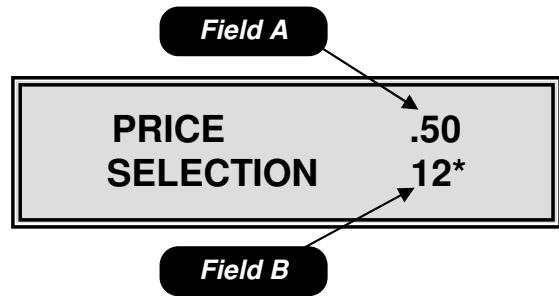

### **Mode 20 – Price Assignment**

**Field A** is the price setting field.

**Field B** is the selection assignment field.

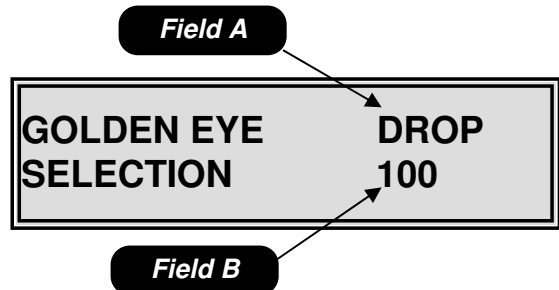

### **Mode 21 – PosiVend Enable Setup**

**Field A** is the PosiVend option setting field.

**Field B** is the selection assignment field.

# Programming

---

## Mode 21 - Continued

### Available Options

**Drop** – The motor will stop as soon as the product is detected after the first complete revolution.

**Home** – The motor will home before stopping.

**Off** – PosiVend is disabled, the motor will stop as soon as it reaches home whether a product has been delivered or not.

See page 3.04 for a complete description of the function of the PosiVend Guaranteed Delivery System.

### Special Actions

- ◆ The \* key may be used as a wildcard to set the entire rows (12\*) or the entire machine (1\*\*).
- ◆ To delete all selections press the # key then the \* key in sequence.

◆ **To home motors left off home in the DROP mode, open the door and press the C key, then close the door.**

## Mode 22 – Bill Escrow Setup

Mode 22 is used to set the bill escrow option. To access this mode, press **22** on the numeric keypad.

Upon entering the bill escrow set up mode, the display will show the current bill escrow state in Field A. Use the # key to toggle between the available options in Field A. To exit this mode, press the **C** key or press the Service Switch.

### Available options

**First** – The machine will hold the first bill deposited in escrow until a vend is initiated. Once a vend is initiated the bill must be stacked before the product will be dispensed. In this mode only one bill will be accepted. If the coin return is depressed, the bill will be returned to the customer.

**Last** – The machine will accept bills to the highest vend price. If the coin return is depressed the last bill inserted will be returned and all previous bills inserted will be returned in change.

**Off** – All bills accepted will be stacked immediately. If the coin return is depressed, change will be paid back.

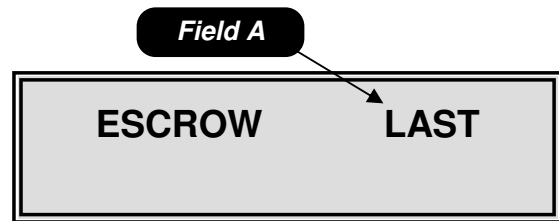

**Mode 22 – Bill Escrow Setup**  
**Field A** is the escrow setting field.

# Programming

## Mode 23 – Motor Pairing

Mode 23 is used to pair an even numbered motor with the next sequential odd numbered motor. To access this mode, press **23** on the numeric keypad.

Upon entering the motor pairing set up mode, the display will show “100 PAIRED TO”. Use the numeric key pad to enter the even numbered motor to be paired in Field A. The odd numbered motor next in sequence will automatically appear in Field B. Use the ◀ or ▶ keys to scroll through the list of paired motors. Use the # key to remove a previously paired combo. To exit this mode, press the **C** key or press the Service Switch.

### Notes

- ◆ Only motors in the same row of a machine may be paired.
- ◆ All pricing, discounting and vending options are set using the selection number of the left motor in the pair.
- ◆ Any even number motor may be paired to the next odd numbered motor in sequence. (e.g. 110 will always be paired with 111, 112 with 113, etc)

## Mode 24 – Winner Mode

Mode 24 is used to set the frequency that free items will be awarded during cash vends only. To access this mode, press **24** on the numeric key pad.

Pressing either the ◀ or ▶ key will allow you to toggle back and forth between the fields.

Upon entering the Winner Mode, the display will show the current winner setting in Field A. Use the numeric key pad to enter the number of vends between winners up to 9999, then toggle to Field B, use the # key to turn the Winner Mode on (Y) or off (N). To exit this mode, press the **C** key or press the Service Switch.

When a customer wins, the credit will be returned the beeper will sound 5 times and the display will show “**WE HAVE A WINNER!!**”.

### Notes

- ◆ Vends made while on free vend, test vend or the second vend of a combo vend are not counted for the purpose of determining the winner.
- ◆ Setting the number to 0000 will result in every vend being a winner.

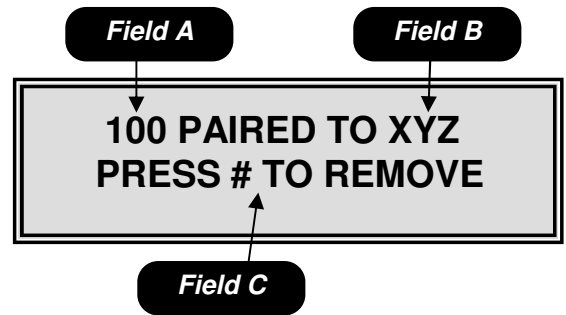

### **Mode 23 – Motor Pairing**

**Field A** is the even motor number to be paired.

**Field B** is the odd number motor to be paired this number will automatically appear once a selection is entered in field A.

**Field C** is the instructions to remove a previously set motor pair.

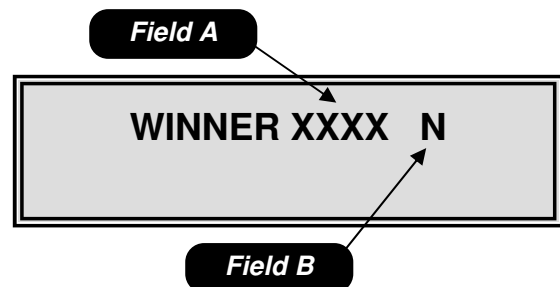

### **Mode 24 – Winner Mode**

**Field A** is the number of vends between winners.

**Field B** is the winner on/off field.



# Programming

## Mode 25 – Force Vend Setup

Mode 25 is used to set the force vend option. To access this mode, then press **25** on the numeric keypad.

Upon entering the force vend mode, the display will show the current force vend state. Use the **#** key to toggle between on and off in Field A. To exit this mode, press the **C** key or press the Service Switch.

### Available options

**On** – The customer must purchase an item before any credit will be returned.

**Off** – The customer may receive their money back at any time.

### Notes

- ◆ Force vend does not apply to the use of debit cards or to bills held in escrow, only to non-tube coins.

## Mode 26 –Multi-vend Setup

Mode 26 is used to set the multi-vend option. Multi-vend allows the customer to make an additional selection using the change amount due from the prior vend. To access this mode, **26** on the numeric keypad.

Pressing either the ◀ or ▶ key will allow you to toggle back and forth between the fields.

Upon entering the multi-vend mode the display will show the current multi-vend state. Use the **#** key to toggle between on and off, then toggle to Field B to change the time-out setting, the default setting is 30 seconds if a larger time-out setting is desired use the numeric key pad to enter the larger time. To exit this mode, press the **C** key or press the Service Switch.

### Available options

**On** – Allows customer to make additional selections as long as sufficient credit exists to purchase the lowest priced item in the machine. The customer may establish additional credit at any time when in this mode. If the customer presses the coin return lever, or the amount of available credit drops below the lowest price in the machine or the time-out expires, change is returned regardless of the state of multi-vend.

**Off** – Change will be returned immediately after the sale.

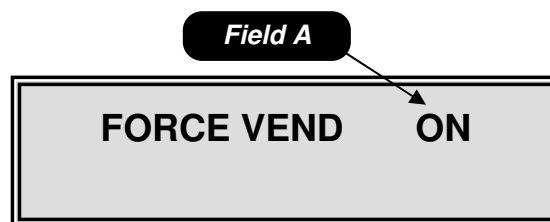

**Mode 25 – Force Vend Setup**  
*Field A* is the force vend on/off field.

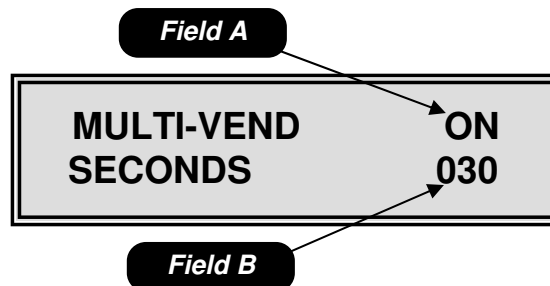

**Mode 26 – Multi-vend Setup**  
*Field A* is the multi-vend on/off field.  
*Field B* is the time-out field; the default time is 30 seconds. The available range is 5 to 90 seconds.

# Programming

## Mode 27 – Combo Vend Setup

Mode 27 is used to set the combo vend feature. A combo vend allows you to set up a selection to be offered in conjunction with another selection. To access this mode, press **27** on the numeric keypad.

Pressing either the ◀ or ▶ key will allow you to toggle back and forth between the fields.

Upon entering the combo vend mode the display will show the current combo vend state. Use the # key to toggle between on (Y) and off (N) in Field A, then toggle to Field B use the numeric key pad to set the time out value in seconds. The time-out value is the number of seconds the customer has to add additional credit in order to purchase a combo vend combination. Then toggle to Field C use the # key to set a unique number for the combination, this number is settable from 0 to 9 allowing for 10 different combinations at any 1 time. Then toggle to Field D and use the numeric key pad to set the item that is to be selected by the customer, then toggle to Field E and use the numeric key pad to select the item to be offered in combination with the customer selected item. Then toggle to Field F and use the numeric key pad to set the discount amount of the combination item. Then toggle to Field G and use the # key turn the selected combination vend on (Y) or off (N). To exit this mode, press the **C** key or press the Service Switch.

### Notes

- ◆ Setting the discount amount in Field F to \$99.99 will allow the discounted item to be vended for free.
- ◆ Wild carding with the \* key is not allowed in the combo vend.
- ◆ When combo vend is active, the display will scroll the message “FEATURED ITEM \*\*\* BUY XXX AND SAVE \$ ON YYY”.

## Mode 28 – Free Vend Option

Mode 28 is used to set the free vend option. To access this mode, press **28** on the numeric keypad.

Upon entering the free vend option mode the display will show the current free vend state. Use the # key to toggle the free vend on or off in Field A. To exit this mode, press the **C** key or press the Service Switch.

### Note

- ◆ Free vend applies to the entire machine.

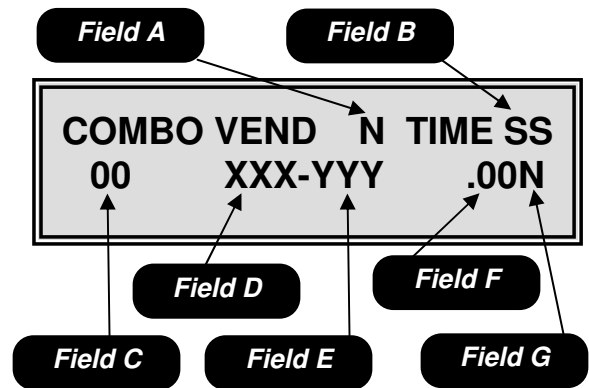

### Mode 27 – Combo Vend Setup

**Field A** is the global combo vend on/off field.

**Field B** is the time-out field measured in seconds.

**Field C** is the number assigned to the combo vend.

**Field D** is the item selected by the customer.

**Field E** is the item to be vended in combination with the customer selected item.

**Field F** is the discount amount of the combination item.

**Field G** allows the user to turn the combination item on or off, but leave the rest of the combination vends in use.

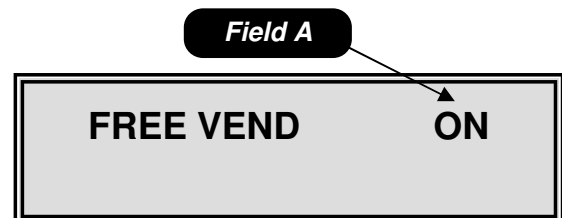

### Mode 28 – Free Vend Option

**Field A** is the free vend option on/off field.

# Programming

## Mode 29 – Free Vend Coupon

Mode 29 is used to set the free vend coupon or token option. To access this mode, press **29** on the numeric keypad.

Upon entering the free vend coupon mode the display will show Free Vend Coupon XXX in Field A, where XXX is the selection enabled for the free vend coupon. Each selection enabled for the free vend coupon is shown in sequence in Field A by depressing the ◀ or ▶ key. Use the numeric keypad to add selections. To remove a selection, press the # key while the selection number is displayed. To exit this mode, press the C key or press the Service Switch.

### Special Actions

- ◆ The \* key may be used as a wildcard to set entire rows (12\*) or the entire machine (1\*\*).

## Mode 30 – Chip Retrieve/Store Mode

Mode 30 is used to retrieve or store information from the touch memory button (*CHIP*). To access this mode, press **30** on the numeric keypad.

To store all programmable information to *CHIP* press the \* key as shown in Field B. To upload information previously stored on a *CHIP* press the # key as shown in field C. To exit this mode, press the C key or press the Service Switch.

- ◆ **To make sure that the information being transferred from the *CHIP* is compatible the software revision numbers will be compared before the transfer. If the version on the *CHIP* is not compatible the transfer is canceled and the display will show “CHIP NOT COMPATIBLE”.**

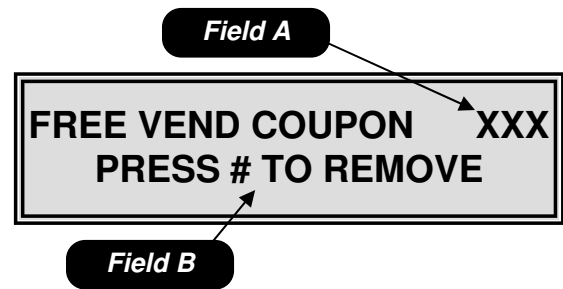

**Mode 29 – Free Vend Coupon**  
**Field A** is the selection enabled field.  
**Field B** is the selection remove field.

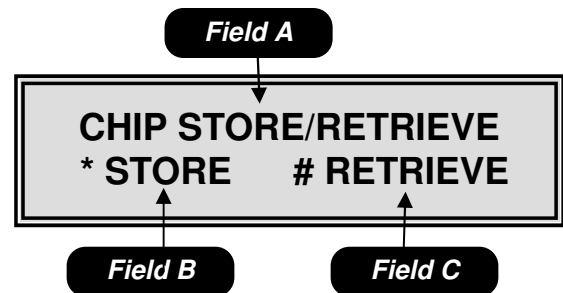

**Mode 30 – Chip Retrieve/Store Mode**  
**Field A** is the name of the mode.  
**Field B** is the download to *CHIP* function.  
**Field C** is the upload from *CHIP* function.

# Programming

## Mode 31 – Change Payback Type

Mode 31 is used to set the change payback option. To access this mode, press **31** on the numeric keypad.

Upon entering the change payback mode, the display will show the current change payback state in Field A. Use the **#** key to toggle through the available options. To exit this mode, press the **C** key or press the Service Switch.

### Available options

**LEAST** – The least amount of coins will be paid back.

**LVL3** – The coin changer makes the payback decision based on how much money it thinks is in each tube. You should use the “Tube Fill” menu item (Mode 10) when you use this option.

## Mode 32 – Selection Lockout

Mode 32 is used to lock selections from use in conjunction with an external switch. To access this mode, press **32** on the numeric keypad.

Upon entering the lockout mode the display will show LOCK SELECTION XXX in Field A. Where XXX is the selection enabled for lock out. Use the ◀ or ▶ key to scroll through each selection affected by the lockout. Use the numeric key pad to add selections. Use the **#** key while the selection number is displayed to remove selections. To exit this mode, press the **C** key or press the Service Switch.

### Special actions

- ◆ The \* key may be used as a wildcard.
- ◆ If all selections are disabled the lights will turn off and no money will be accepted.

### Note

- ◆ The mechanical lockout of selections is done by adding an external key switch or other switch across pins P2-3 & P2-4 on the logic board.
- ◆ The machine will not function properly in shutdown when the door is open. The machine must **not** have the shut down switch active while the door is open.

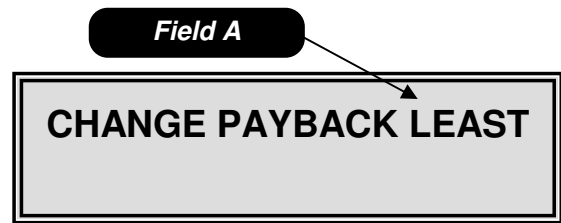
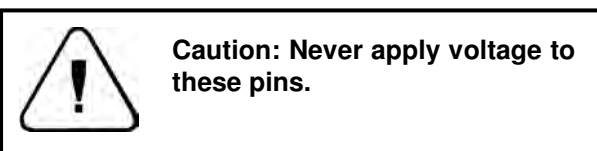

**Mode 31 – Change Payback Type**  
**Field A** is the payback option selection field.

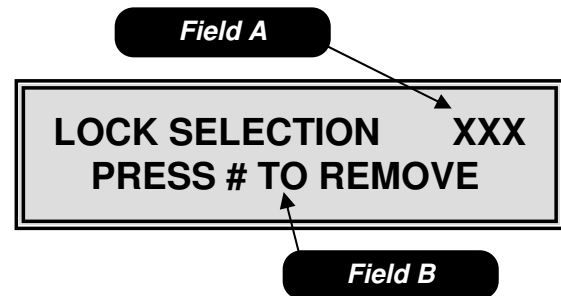

**Mode 32 – Selection Lockout**  
**Field A** is the selection disable field.  
**Field B** is the selection remove field.

# Programming

## Mode 33 – Set Spiral Count

Mode 33 is used to set the Spiral Count. Spiral Count allows you to program the number of spaces in each spiral. When a selection has vended all product out of the individual spiral, the display will show 'SOLD OUT". To access this mode, press **33** on the numeric keypad.

Pressing either the ◀ or ▶ key will allow you to toggle back and forth between the fields.

Upon entering the set spiral count mode the controller will display SPIRAL CNT OFF/ON in Field A. Use the # key to toggle between OFF/ON. If Field A is set to off no further action is needed.

If Field A is set to ON, Toggle to Field C and use the numeric key pad to enter the spiral count. Then toggle back to Field B and enter the selection numbers that correspond to the spiral count set in Field C. Repeat the above steps for each selection. To exit this mode, press the **C** key or press the Service Switch.

When Spiral Count is ON (Field A), each time the main cabinet door is opened, the display will prompt "STOCK MACHINE –Y". Pressing the # key with the Y showing will reset the spiral counts. Closing the door without pressing the # key, the sold out status of each spiral remains.

### Special actions

- ◆ The \* key can be used as a wildcard in Field B to set entire rows (12\*) or the entire machine (1\*\*).
- ◆ To disable a selection from spiral count set Field C to 0.

### Note

- ◆ If this function is enabled, route service personnel must be instructed in its correct operation. Failure to correctly reset the counts will result in a full machine from vending properly.

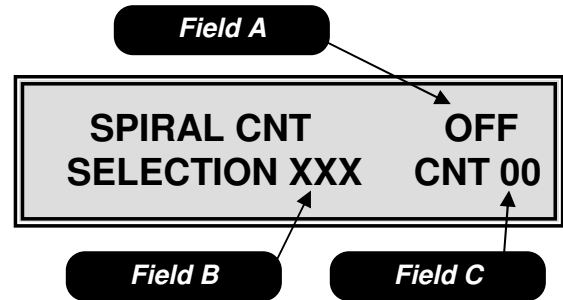

### **Mode 33 – Set Spiral Count**

**Field A** is the spiral count on/off field.

**Field B** is the item selection field.

**Field C** is the spiral count field.

# Programming

## Mode 34 – Speech / Chime

Mode 34 is used to set the Speech/Chime options. To access this mode, press **34** on the numeric keypad.

Pressing either the ◀ or ▶ key will allow you to toggle back and forth between the fields.

Upon entering the speech/chime options mode, the controller will display the current SPEECH setting in field A and the current CHIME setting in Field B. The # key is used to toggle between on and off for each field. To exit this mode, press the **C** key or press the Service Switch.

### Notes

- ◆ Turning the chime off will disable the beep from sounding in all conditions, except for the health code warning set in Mode 42.
- ◆ When speech is on, all messages in the service mode will be transmitted via the DEX port for use with an audio interface.
- ◆ When speech is on, the DEX/UCS port can no longer be used for any other communication.

## Mode 35 – Security

Mode 35 is used to set the Security options. To access this mode, press **35** on the numeric keypad.

Pressing either the ◀ or ▶ key will allow you to toggle back and forth between the fields.

Upon entering the security mode, the current security settings will be displayed. Use the numeric key pad to set the desired security code in Field A, then toggle to Field B, use the # key to toggle between on (Y) and off (N). To exit this mode, press the **C** key or press the Service Switch.

With the security code, the service person will only be allowed access to Modes 01 to 04. Trying to enter any other modes will change the display to “ENTER SECURITY CODE”. Once the proper code has been entered all modes in the machine will be accessible until the service mode is exited.

### Note

- ◆ Factory default settings are off (N) and a security code of 1111.
- ◆ **Once the service mode as been exited, the code must be re-entered to access Modes 05 through 84.**

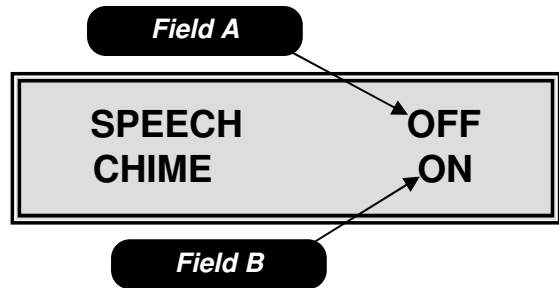

**Mode 34 – Speech/Chime**  
**Field A** is the speech option field.  
**Field B** is the chime option field.

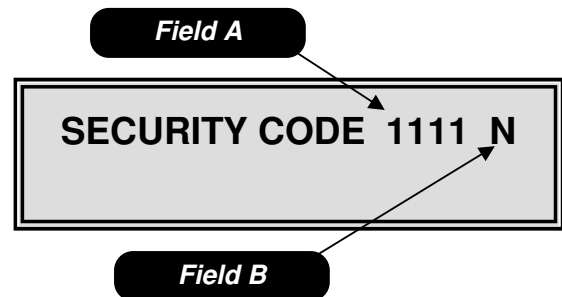

**Mode 35 - Security**  
**Field A** is the security code entry field.  
**Field B** is the security on/off field.

# Programming

## Mode 36 – Space to Sales

Mode 36 is used to set two columns to run together in a Space to Sales manner. To access this mode, press **36** on the numeric keypad.

Pressing either the ◀ or ▶ key will allow you to toggle back and forth between the fields.

Upon entering the Space to Sales mode, the display will show the current Space to Sales settings. Use the # key in Field A to turn the Space to Sales feature on (Y) or off (N). Toggle to Field B and use the # key to set a unique number for the space to sales combination. This number is settable from 0 to 9 allowing for 10 different Space to Sales combinations at any one time. Toggle to Field C and use the numeric keypad to set the first item number to be vended in a space to sales manner, then toggle to Field D and use the numeric keypad to set the second item number to be vended in a space to sales manner. Toggle to Field E, and use the # key to turn the selection numbers set in Field B to on (Y) or off (N). To exit this mode, press the **C** key or press the Service Switch.

◆ **Space to sales allows you to program two selection spirals to operate as one in an alternating method. For example if selection 110 is entered into Field C and selection 112 is entered into Field D, every time selections 110 or 112 are selected the product will be vended from spiral 110 one time and 112 the next time. It is important that any selections enabled in this mode contain the same product. The goal of space to sales is to increase the capacity of an individual item while preventing the inevitable empty spiral from occurring on a fast moving product.**

## Mode 37 – Set Max Payout Mode

Mode 37 is used to set the Maximum Payout options. To access this mode, press **37** on the numeric keypad.

Pressing either the ◀ or ▶ key will allow you to toggle back and forth between the fields.

Upon entering the maximum payout mode, the controller will display the current max payout setting.

Toggle to Field A use the numeric keypad to set the maximum value of coins to be returned, then toggle to Field B and use the # key to turn on (Y) or off (N) the option. To exit this mode, press the **C** key or press the Service Switch.

### Note

◆ When turned on (Y), if the credit after the sale is greater than the Max Payout set point in Field A, the machine will go into an automatic multi-vend (mode 26).

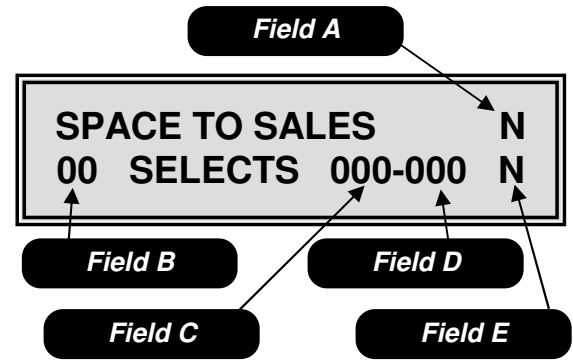

### Mode 36 – Space to Sales

**Field A** is the space to sales on/off field.

**Field B** is the product type number field.

**Field C** is the first selection setting field.

**Field D** is the second selection setting field.

**Field E** is the product type on/off field

◆ **Caution – Space to Sales items must be priced identically.**

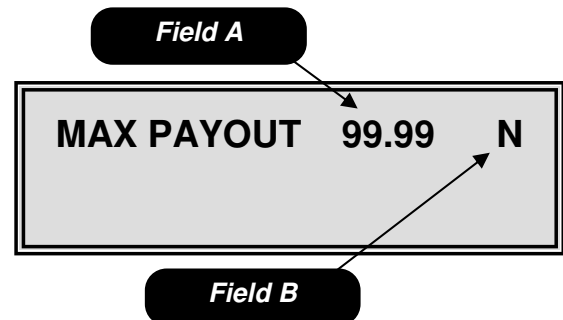

### Mode 37 – Set Max Payout

**Field A** is the maximum coin payout field.

**Field B** is the maximum coin payout on/off field.

# Programming

## Mode 40 – Set Temperature

Mode 40 is used to set the Temperature of the cabinet(s). To access this mode, press **40** on the numeric keypad.

Pressing either the ◀ or ▶ key will allow you to toggle back and forth between the fields.

Upon entering mode 40, the display will show the current temperature range setting. Field A is the cabinet selection field, use the # key to choose between 1 (cabinet 1) or 2 (cabinet 2). Toggle to Field B to choose the temperature range option - see below for the available options. Then toggle to Field C to set the temperature for the chilled cabinet. Use the 1 key to raise or the 2 key to lower the temperature. Then toggle to Field E; use the # key to choose between Fahrenheit (F) and Celsius (C) temperature scales. To exit this mode, press the C key or press the Service Switch.

### Field B Temperature Range Options

**AMBIENT** – No temperature control. Field C will show ----- F.

**ZONE** – The target temperature in Field C for each zone in the machine is settable from +36° to +80° F (4° to 21° C). This setting is only available if Field A is set to cabinet 1, and should only be used when selling non-perishable products. See page 2.02 for additional information.

**FOOD** – The target temperature in Field C is fixed at +36° F (2° C). This setting is used when the whole cabinet or a portion of it contains perishable product. When used in a GPL6500 with a barrier, shelves located lower than the barrier must be enabled for Health Code in Mode 42 – see page 5.20

**FROZEN** – The target temperature range in Field C is settable from -15° to +10° F (-12° to -26° C) – Only applies to an external cabinet (AP960 or AP320)

◆ All temperature ranges have a + or – range of 3° F (2° C).

◆ The temperature inside the machine can be viewed from the outside by pressing and holding the \* key for °F or # key for °C.

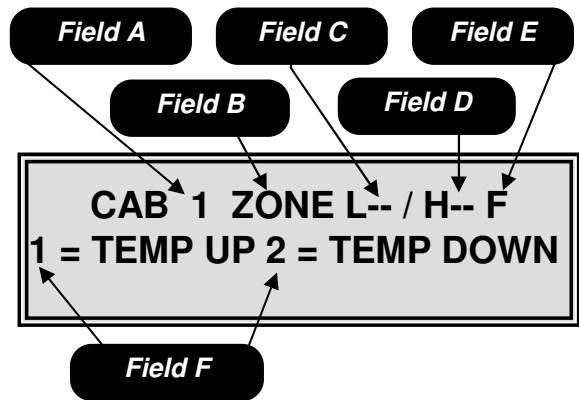

### Mode 40 – Set Temperature for Cabinet 1

**Field A** is the cabinet selection field.

**Field B** is the temperature range selection field.

**Field C** is the temperature setting field for the cabinet in the GPL6500.

**Field D** is only used on a dual zone machine, and is not used in the GPL6500

**Field E** is the temperature scale field, F for Fahrenheit or C for Celsius.

**Field F** is the instructions for raising and lowering the temperature.

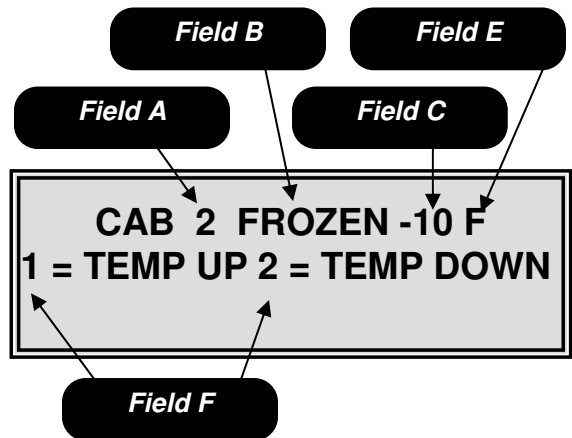

### Mode 40 – Set Temperature for Cabinet 2

**Field A** is the cabinet selection field.

**Field B** is the temperature range selection field.

**Field C** is the temperature setting field. The default setting for frozen is -10°F.

**Field D** is the temperature scale field, F for Fahrenheit or C for Celsius.

**Field F** is the instructions for raising and lowering the temperature.



**All items located above the barrier assembly must be non-perishable!**



# Programming

## Mode 41 – Defrost

### Used on Models 320/960 only!

Mode 41 is used to set the Defrost schedule and to start a Manual Defrost on 320/960 cabinets(s) only. The defrost on the Fusion is automatic; for more information on the Fusion defrost refer to the refrigeration process page 2.02. To access this mode, press **41** on the numeric keypad.

Pressing either the ◀ or ▶ key will allow you to toggle back and forth between the fields.

Upon entering the Defrost setup mode, the display will show the current defrost settings. **Field A** is the cabinet selection field, use the # key to choose between cabinet 1 (1) or cabinet 2 (2). Then toggle to **Field B**, use the # key to set the defrost start time, in the 24 hour format. Then toggle to **Field C**, use the # key to choose between 6 or 8 hour time intervals between defrosting. To start an immediate defrost push the \* key, the display will show “Defrost Starts in 2 Minutes”. To exit this mode, press the **C** key or press the Service Switch.

## Mode 42 – Health Shutdown

Mode 42 is used to set the health shutdown options for the cabinet(s). To access this mode, press **42** on the numeric keypad.

Pressing either the ◀ or ▶ key will allow you to toggle back and forth between the fields.

Upon entering the health shutdown mode, the display will show the current health shutdown state. Use the numeric key pad to enter the selection numbers to be “health controlled” in **Field A**. Toggle to **Field B**, use the # key to turn the health shutdown on or off for the selected items. Repeat the above steps for each selection. If you would like a chime to sound when a health shutdown has occurred toggle to **Field C**, use the # key to turn the chime on or off. To exit this mode, press the **C** key or press the Service Switch.

### Special actions

- ◆ The \* key can be used as a wildcard in **Field A** to set entire rows (12\*) or the entire machine (1\*\*).

◆ **If shelf is out of order due to health code, no message is posted until a selection is made. Once selection is made the display will say “Make Another Selection”.**

◆ **If the machine detects a Health Code error and the chime feature is ON the control board will sound a double beep every 30 seconds until the Health Code error is corrected.**

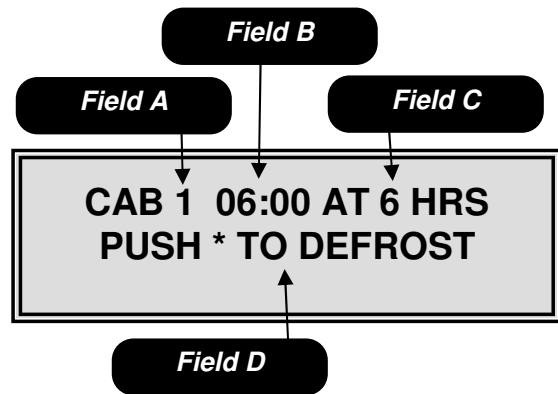

### **Mode 41 - Defrost**

**Field A** is the cabinet selection field.

**Field B** is the time in the 24 hour format to start the defrost cycle.

**Field C** is the interval in hours between each defrost cycle settable to 6 or 8.

**Field D** is the information to start an immediate defrost cycle.

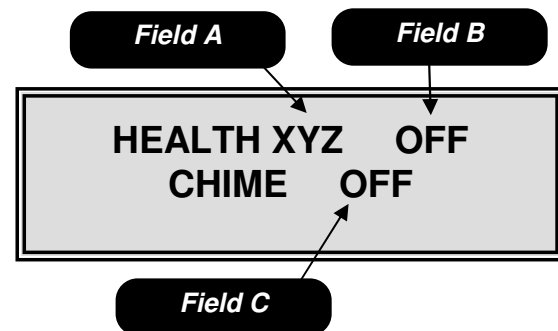

### **Mode 42 – Health Shutdown**

**Field A** is the item selection field.

**Field B** is the health shutdown on/off field.

**Field C** is used to turn on/off the health shutdown notification chime.

# Programming

## Mode 50 – Current Time

Mode 50 is used to set the current time date, date format and daylight saving options. To access this mode, press **50** on the numeric keypad.

Pressing either the ◀ or ▶ key will allow you to toggle back and forth between the fields.

Upon entering the Current Time mode, the display will show the current time (in 24 hour military time) and date settings. Use the numeric key pad to change the hour setting in Field A, then toggle to Field B and use the numeric key pad to set the minutes. Press the # key to set the time. Toggle to Field C, use the numeric key pad to set the month, then toggle to Field D, use the numeric key pad to set the day, then toggle to Field E, use the numeric key pad to set the year. Use the # key to save the date. Toggle to Field F; use the # key to choose the date format from the available options shown below. Toggle to Field G to change the daylight savings time zone setting using the available options shown below. To exit this mode, press the **C** key or press the Service Switch.

◆ **You must press the # key each time to save any changes to the time or date!**

### Field F available options

**MONTH/DAY** – This option will show the date in the Month/Day/Year format (mmddy).

**DAY/MONTH** – This option will show the date in the Day/Month/Year format (ddmmy).

### Field G available options

**OFF** – Does not follow daylight savings time.

**N.AMER** – Will automatically adjust to North American daylight savings time with a 1 hour increase on the 2nd Sunday in March and a 1 hour decrease the 2nd Sunday in November.

**UK/EUR** – Will automatically adjust to European daylight savings time with a 1 hour increase on the last Sunday in March and a 1 hour decrease on the last Sunday in October.

**AUSLIA** – Will automatically adjust to Australian daylight savings time with a 1 hour increase on the last Sunday in October and a 1 hour decrease on the last Sunday in March.

◆ **North American Daylight Savings Time was changed in revision 20 software to follow the new daylight savings times enacted in 2007.**

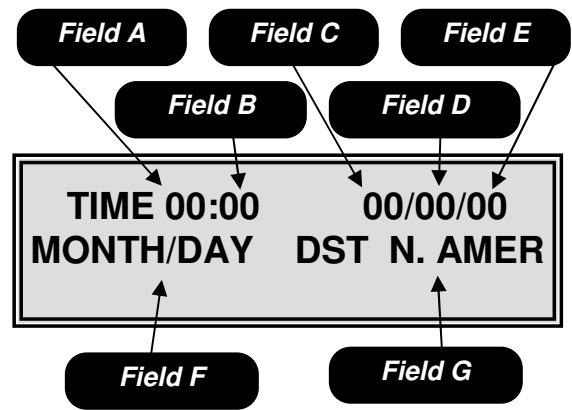

### Mode 50 – Current Time

**Field A** is the hour setting field (24 hour military time).

**Field B** is the minute setting field.

**Field C** is the month setting field.

**Field D** is the day setting field.

**Field E** is the year setting field.

**Field F** is the date format field.

**Field G** is the daylight savings selection field.



**It is recommended that the battery be replaced every 5 years.**

# Programming

## Mode 51 – Timed Shutdown

Mode 51 is used to set timed machine shutdown periods. The shutdown periods affect the ability of the machine to vend and the appearance of the machine. To access this mode, press **51** on the numeric keypad.

Pressing either the ◀ or ▶ key will allow you to toggle back and forth between the fields.

Upon entering the timed shutdown mode, the display will show the current shutdown setting. Use the # key in Field A to set the shutdown period number; this number may be set from 1 to 4 allowing for up to 4 different shutdown time periods per week. Toggle to Field B using the numeric key pad set the beginning hour then toggle to Field C and set the beginning minute (using 24 hour military time). Toggle to Field D using the numeric key pad set the ending hour then toggle to Field E to set the ending minute (using 24 hour military time). Toggle to Field F use the ◀ or ▶ keys to scroll between the days of the week, choosing which days the shutdown will occur on, use the # key to turn the days on (UPPERCASE) or off (lowercase). Toggle to Field G press the # key to reach screen 2. Field A on screen 2 references Field A on Screen 1 and should not be changed. Toggle to Field H use the # key to turn the shut down period on (Y) or off (N). Toggle to Field I use the # key to set the shutdown type from the available options shown below.

### Field I available options

**LIGHTS OFF** – this option is used to shut down the lights only. The machine will function in all other ways.

**VEND OFF** – this option shuts down the lights, disables vending by selection and if all selections are disabled credit acceptance will also be disabled.

**LOW ENERGY** – this option will shut down the lights, vending will be allowed. In cabinets without health control enabled the temperature will be allowed to rise 5 degrees above the set point during the shut down period.

**TOT SHTDWN** – this option will shut down the lights, compressor (in non health control machines), vending, credit acceptance and the display.

Toggle to Field J use the numeric key pad to enter the selection number the shutdown applies to, toggle to Field K and use the # key to change the N to Y, then toggle back to Field J and enter the remaining selections. You may use the # key while in Field J to scroll through the previous set selections. Field L may be used to return to Screen 1. To exit this mode, press the **C** key or press the Service Switch.

### Special Actions

- ◆ The \* key can be used as a wildcard in Field J to set entire rows (12\*) or the entire machine (1\*\*).

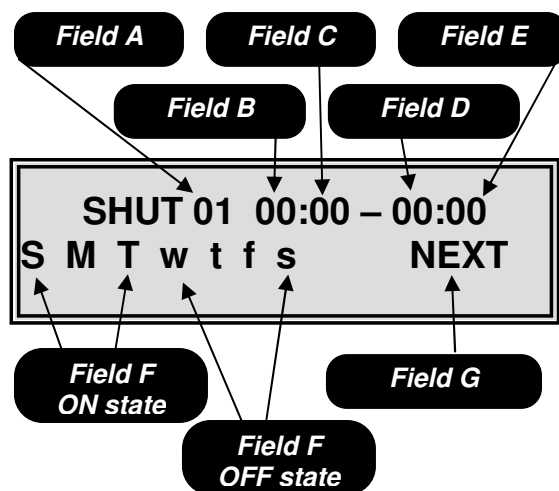

### Mode 51 – Timed Shutdown Screen 1

**Field A** is the shutdown number selection field.  
**Field B** is the shutdown starting hour set field.  
**Field C** is the shutdown starting minute set field.  
**Field D** is the shutdown ending hour set field.  
**Field E** is the shutdown ending minute set field.  
**Field F** is the day of the week selection field. In this example Sunday, Monday and Tuesday are ON and Wednesday, Thursday, Friday and Saturday are OFF.  
**Field G** is the move to the next screen field.

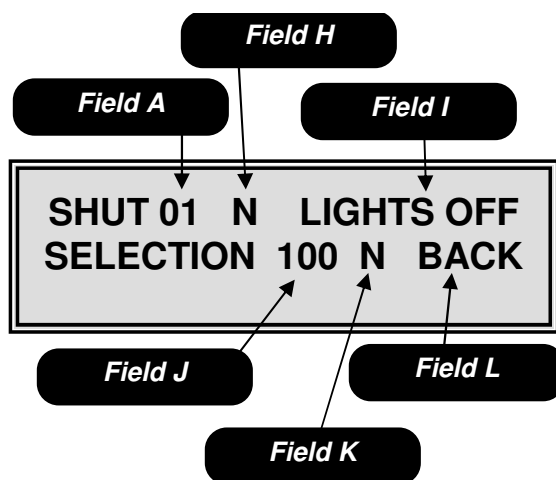

### Mode 51 – Timed Shutdown Screen 2

**Field A** is a reference to Field A on screen 1 and should not be changed.  
**Field H** is the shutdown on/off field.  
**Field I** is the shutdown type field.  
**Field J** is used to select item numbers for the shutdown.  
**Field K** is used to add/remove items from the shutdown.  
**Field L** is used to return to screen 1 in mode 51.



**Use of low energy or total shutdown in any machine with perishable products is not allowed.**

# Programming

## Mode 51 – Continued

### Note

- ◆ When the shutdown activates and only a portion of the machine is shut down, the display will scroll the message “**SELECTION XXX XXX XXX NOT AVAILABLE**” where XXX are the selections shut down, only 10 selections can be displayed if there are more than 10 a + sign will be added.
- ◆ In the Vend Off mode, if all selections are disabled the display will read “**MACHINE USE NOT ALLOWED UNTIL HH:MM**” where HH:MM is the time the shutdown is scheduled to shut off in Field B.
- ◆ Shutdown times in Field B and C must stay within a 24 hour clock: 00:00 to 23:59.

## Mode 52 – Timed Discount

Mode 52 is used to set timed discounts. To access this mode, press **52** on the numeric keypad.

Pressing either the ◀ or ▶ key will allow you to toggle between the fields.

Upon entering the timed discount mode, the display will show the current timed discount settings. Use the # key in Field A to set the discount time period number; this number may be set from 1 to 4 allowing for up to 4 different discount periods per week. Toggle to Field B using the numeric key pad set the beginning hour then toggle to Field C and set the beginning minute (using 24 hour military time). Toggle to Field D using the numeric key pad set the ending hour, then toggle to Field E to set the ending minute (using 24 hour military time). Toggle to Field F, using the ◀ or ▶ keys to scroll between the days of the week, choosing which days the discount will occur on, use the # key to turn the days on (UPPERCASE) and off (lowercase). Toggle to Field G press the # key to reach screen 2. Field A on screen 2 references Field A on Screen 1 and should not be changed. Toggle to Field H use the # key to turn the discount period on (Y) or off (N). Toggle to Field I, and use the numeric key pad to set the discount dollar amount. Toggle to Field J use the numeric key pad to enter the selection number to be discounted, toggle to Field K and use the # key to change the N to Y, then toggle back to Field J and enter the remaining selections. You may use the # key while in Field J to scroll through the previous set selections. Field L may be used to return to Screen 1. To exit this mode, press the C key or press the Service Switch.

### Special Actions

- ◆ The \* key can be used as a wildcard in Field J to set entire rows (12\*) or the entire machine (1\*\*).

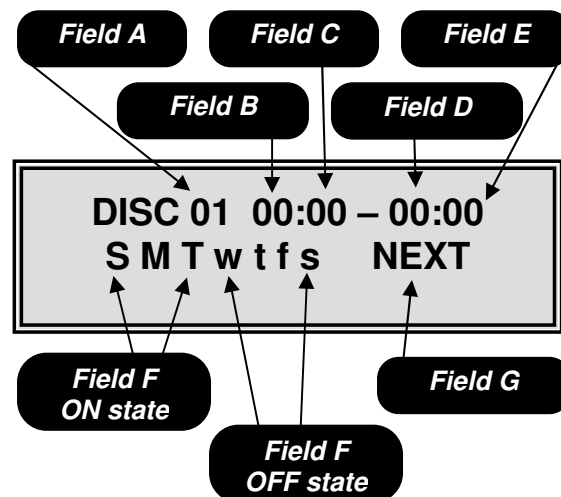

### Mode 52- Timed Discount Screen 1

- Field A** is the timed discount number selection field.
- Field B** is the timed discount starting hour set field.
- Field C** is the timed discount starting minute set field
- Field D** is the timed discount ending hour set field.
- Field E** is the timed discount ending minute set field.
- Field F** is the day of the week selection field. In this example Sunday, Monday and Tuesday are ON and Wednesday, Thursday, Friday and Saturday are OFF.
- Field G** is the move to the next screen field

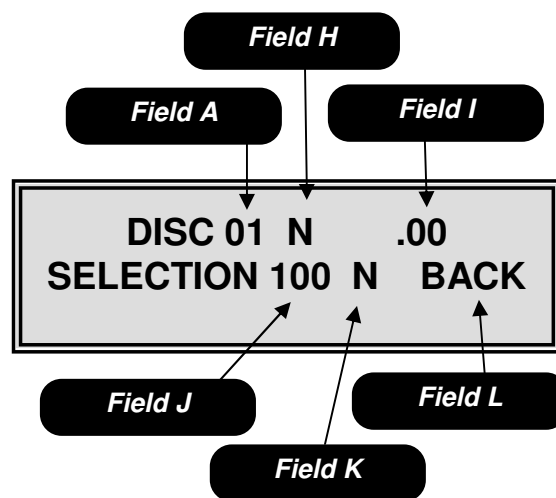

### Mode 52 – Timed Discount Screen 2

- Field A** is a reference to Field A on screen 1 and should not be changed.
- Field H** is the timed discount on/off field.
- Field I** is the discount amount field.
- Field J** is used to select item numbers for the timed discount.
- Field K** is used to add additional selection numbers to the timed discount list.
- Field L** is used to return to screen 1 in mode 52.

# Programming

## Mode 52 – Continued

### Note

- ◆ When the discount period becomes active, the display will scroll “SAVE \$.XX ON YYY YYY YYY” where xx is the dollar amount set in Field H and YYY is the items selected in Field I. A maximum of 10 selections will be displayed if more than 10 items a + will be added.
- ◆ Shutdown times in Field B and C must stay with in a 24 hour clock: 00:00 to 23:59.

## Mode 53 – Timed Messages

Mode 53 is used to set timed user messages. To access this mode, press **53** on the numeric keypad.

Pressing either the ◀ or ▶ key will allow you to toggle back and forth between the fields.

Upon entering the timed user message mode, the display will show the current timed user message state. Use the # key in Field A to set the timed user message period number; this number may be set from 1 to 5 allowing for up to 5 different timed message periods per week. Toggle to Field B using the numeric key pad set the beginning hour then toggle to Field C and set the beginning minute (using 24 hour military time). Toggle to Field D using the numeric key pad set the ending hour then toggle to Field E and set the ending minute (using 24 hour military time). Toggle to Field F using the ◀ or ▶ keys to scroll between the days of the week, choosing which days the message will occur on, use the # key to turn on (UPPERCASE) or of (lowercase) the desired days. To exit this mode, press the **C** key or press the Service Switch.

### Note

- ◆ The times in Field B and C must stay with in a 24 hour clock (00:00 to 23:59).
- ◆ A user message must be set in Mode 60 before a timed message can be set. If no user messages are set, the default user message described in Mode 60 will be displayed.

## Mode 60 – User Message

Mode 60 is used to set a user message. To access this mode, press **60** on the numeric keypad.

Pressing either the ◀ or ▶ key will allow you to toggle back and forth between the fields.

Upon entering the user message mode, the display will show the current user message state. Use the # key in Field A to select the user message number; this number may be set from 1 to 4 allowing for up to 4 programmable user messages. Toggle to Field B to select which line your message will be displayed on. Use the # key to choose from one of the available options shown below.

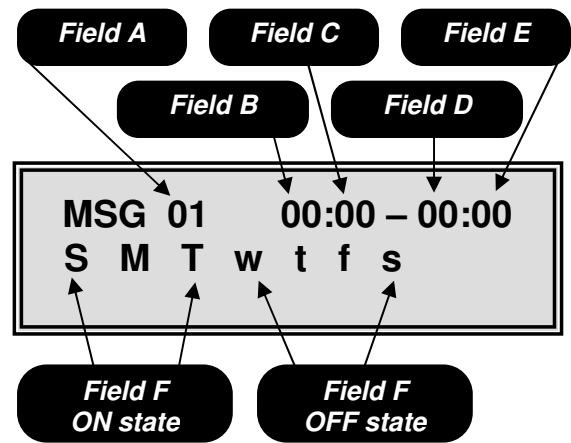

### Mode 53 – Timed Messages

- Field A** is the message select field.
- Field B** is the starting hour in 24 hour military time.
- Field C** is the starting minute in 24 hour military time.
- Field D** is the ending hour in 24 hour military time.
- Field E** is the ending minute in 24 hour military time.
- Field F** is the day selection field. In this example Sunday, Monday and Tuesday are on and Wednesday, Thursday, Friday and Saturday are off.

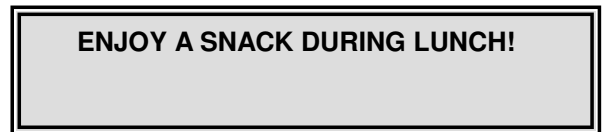

One Possible Timed Message

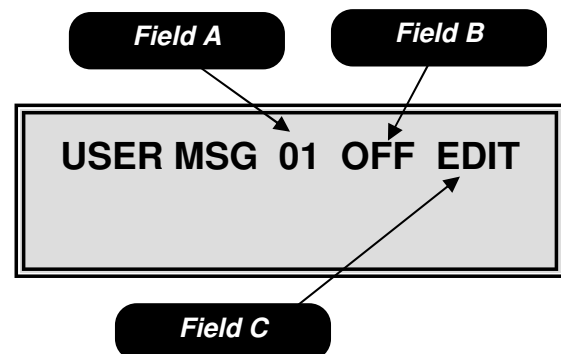

### Mode 60 – User Message Screen 1

- Field A** is the user message select field.
- Field B** is the display location selection field.
- Field C** is the enter edit screen field.

# Programming

## Mode 60 – Continued

### Field B available options

**1** – Your message will be displayed on the top line of the display.

**2** – Your message will be displayed on the bottom line of the display.

**OFF** – Your message will not be displayed.

**THIS IS LINE 1**  
**THIS IS LINE 2**

Toggle to Field C use the # key to enter the editing screen. Upon entering the edit screen the cursor will be flashing Field D. Field E is the edit instruction field use the keys shown, see below for additional information. When done editing press the # to save the message to memory. To exit this mode, press the C key or press the Service Switch.

### Edit Keys

**KEY 1** = to scroll up through the available characters.

**KEY 2** = to scroll down through the available characters.

**KEY 4** = will insert a duplicate of the currently selected character (flashing) and shift all characters to the right by one.

**KEY 5** = will delete the currently selected (flashing) character and shift all characters to the left by one.

**KEY 6** = will insert a flashing blank space to the left of the currently selected (flashing) character and shift all characters to the right by one.

### Note

- ◆ User message numbers 1 thru 4 are user programmable and each can be 100 characters in length.
- ◆ User message number 5 is the time and date message. This message cannot be changed.
- ◆ User message number 6 is the factory default message. This message cannot be changed.
- ◆ If more than 1 user message is programmed for the same line, the message with the higher number will be displayed.
- ◆ When line 2 is not assigned to any message, it will show the message Credit .00, amount of deposited coins.

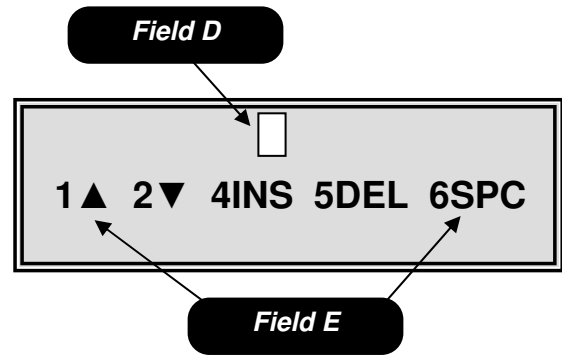

### Mode 60 – User Messages Screen 2

**Field D** represents the flashing cursor this is the position where characters will be added or deleted.

**Field E** is the editing instruction field.

<u>Number</u>	<u>Message</u>
01	HAVE A NICE DAY
02	HAVE A GREAT DAY
03	HAVE A GREAT DAY
04	Have a nice day
05	Current time/date setting
06	HAVE A NICE DAY

### Default User Messages

◆ The } character may be used as an end of message character in any text message greater than 10 characters in length.

◆ To save time scrolling through the available letters, insert an M then use the 4 key to insert several duplicate M's. This will give you a starting point in the middle of the alphabet.

# Programming

## Mode 61 – After Sale Message

Mode 61 is used to customize the message that appears after each vend. To access this mode, press **61** on the numeric keypad.

Pressing either the ◀ or ▶ key will allow you to scroll through the current message.

Upon entering the after sale message mode, the display will show the current message along with a flashing character in Field A. Field B is the edit instruction field, use the keys shown, see below for additional information. When done editing press the # key to save the message to memory. To exit this mode, press the **C** key or press the Service Switch.

### Edit Keys

**KEY 1** = to scroll up through the available characters.

**KEY 2** = to scroll down through the available characters.

**KEY 4** = will insert a duplicate of the currently selected character (flashing) and shift all characters to the right by one.

**KEY 5** = will delete the currently selected (flashing) character and shift all characters to the left by one.

**KEY 6** = will insert a flashing blank space to the left of the currently selected (flashing) character and shift all characters to the right by one.

### Note

- ◆ The after sale message may contain up to 80 additional characters.
- ◆ The after sale message will be appended for food/frozen machines with “PRESS COIN RETURN TO REOPEN DOOR”

## Mode 62 – Out of Service

Mode 62 is used to add additional information to the Out of Service message to aid your customers in the event a machine is out of order. To access this mode, press **62** on the numeric keypad.

Pressing either the ◀ or ▶ key will allow you to scroll through the current message.

Upon entering the out of service message mode, the display will show the current out of service message along with a flashing character in Field A. Field B is the edit instruction field. Use the keys shown, see below for additional information. When done editing press the # key to save the message to memory. To exit this mode, press the **C** key or press the Service Switch.

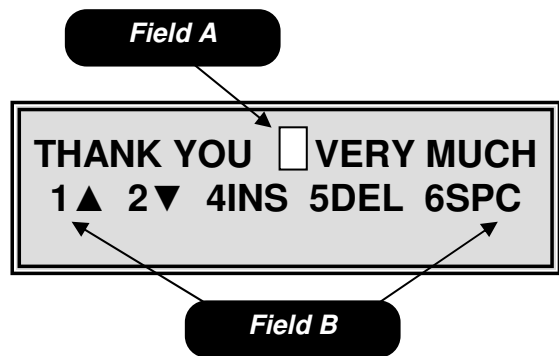

### Mode 61 – After Sale Message

**Field A** represents the flashing cursor this is the position where characters will be added or deleted.

**Field B** is the editing instruction field.



Default After Sale Message



One Possible After Sale Message

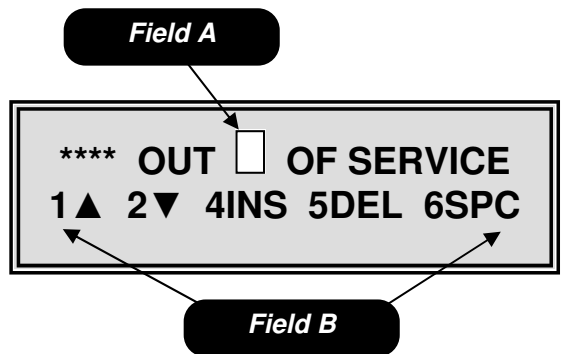

### Mode 62 – Out of Service

**Field A** represents the flashing cursor this is the position where characters will be added or deleted.

**Field B** is the editing instruction field.

# Programming

## Mode 62 – Continued

### Edit Keys

**KEY 1** = to scroll up through the available characters.

**KEY 2** = to scroll down through the available characters.

**KEY 4** = will insert a duplicate of the currently selected character (flashing) and shift all characters to the right by one.

**KEY 5** = will delete the currently selected (flashing) character and shift all characters to the left by one.

**KEY 6** = will insert a flashing blank space to the left of the currently selected (flashing) character and shift all characters to the right by one.

### Note

- ◆ The out of service message may contain up to 80 additional characters.
- ◆ The out of service message will only be displayed if the entire machine is out of service or if no motors or cabinets are available.

## Mode 63 – Alternate Language

Mode 63 is used to set an alternate language. To access this mode, press **63** on the numeric keypad.

Upon entering the alternate language mode, the display will show the alternate language state. Press the **#** key to toggle between on and off. With the alternate language mode turned on all messages will be displayed in the alternate programmed language. To exit this mode, press the **C** key or press the Service Switch.

## Mode 80 – Test Vend

Mode 80 is used test vend the machine. To access this mode, press **80** on the numeric keypad.

Upon entering the test vend mode the display will show select. Use the numeric key pad to enter the selection in Field A (this field will be blank until a numeric key is pressed). If the selection motor tests ok the display will read “TEST PASSED” in Field B, if the motor failed the display will read “MTR ERROR” in Field B. To exit this mode, press the **C** key or press the Service Switch.



**Default Out of Service Message**



**One Possible Out of Service Message**

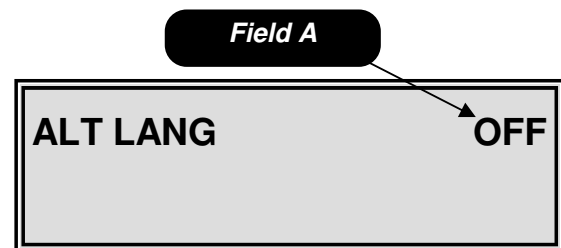

**Mode 63 – Alternate Language**  
*Field A* is the on/off field.

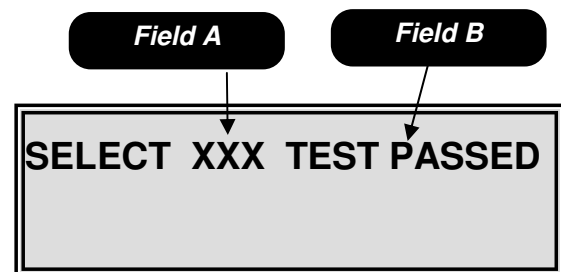

**Mode 80 – Test Vend**  
*Field A* is the item selection field. This field will be blank until a numeric key is pressed.  
*Field B* is the pass/fail field. If the motor passed it will read TEST PASSED if the motor failed it will read MTR ERROR.



# Programming

## Mode 81 – Sequential Event Log

Mode 81 is used to view the sequential event log. In this mode you are able to review the last 25 events that took place in the machine. To access this mode, press **81** on the numeric keypad.

Upon entering the sequential event log, the display will show the last event that took place in the machine. Field A is the sequential event number. Field B is the event that took place (for an explanation of the abbreviation see table 7). Field C shows the selection number the event corresponds to (if applicable). Field D shows the date of the event. Field E shows the time of the event. Use the ◀ key to scroll through the previous sequential events (maximum of 25). Press # then the \* key to clear the sequential event log. To exit this mode, press the **C** key or press the Service Switch.

◆ **The chime will sound 3 times when there are no more items to display.**

DISPLAY	EVENT
<b>CAB1 DR OPEN</b>	Cabinet 1 Door Open
<b>CAB1 DR CLS</b>	Cabinet 1 Door Closed
<b>CAB2 DR OPEN</b>	Cabinet 2 Door Open
<b>CAB2 DR CLS</b>	Cabinet 2 Door Closed
<b>PWR UP</b>	Power UP
<b>MTR XYZ</b>	Run Motor XYZ
<b>GE TRIG</b>	PosiVend Triggered
<b>DEX</b>	Machine Dexed
<b>BAF OPEN</b>	Baffle Door Open
<b>BAF CLSD</b>	Baffle Door Closed
<b>EVNT CLEAR</b>	Event Log Cleared
<b>ERROR CLEAR</b>	Error Log Cleared
<b>MOTOR ERROR</b>	Motor Error
<b>PRICE SET</b>	Price Set
<b>TIME/DATE SET</b>	Time Date Set
<b>RESET ACCOUNT</b>	Reset Accountability
<b>HEALTH ERROR</b>	Health Error
<b>COMM ERROR</b>	Communication Error
<b>C1 DEFROST</b>	Cabinet 1 Defrost
<b>C2 DEFROST</b>	Cabinet 2 Defrost

Table 7: Event list.

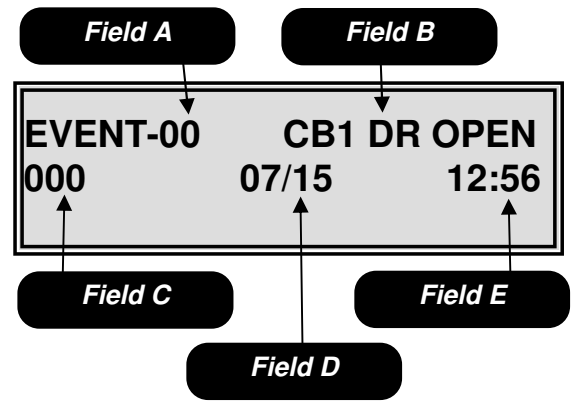

### Mode 81 – Sequential Event Log

**Field A** is the sequential event number.

**Field B** is the event name.

**Field C** is the selection number the event corresponds to if applicable.

**Field D** is the date of the event.

**Field E** is the time of the event.

# Programming

## Mode 82 – Service History

Mode 82 is used to view the service history. To access this mode, press **82** on the numeric keypad.

Upon entering the service history mode, the display will show a service event in Field A. Field B shows you the duration time of the event if applicable; Field B may also show the selection number if applicable to the event in Field A. Field C shows you the time of the event. Field D shows the date of the event. Pressing either the ► key allows you to scroll through the service history events. To exit this mode, press the **C** key or press the Service Switch.

The service history events will be displayed in the following order.

1. The last 5 Cabinet 1 Door Openings, starting with the most recent.
2. The last 5 Cabinet 2 Door Openings, starting with the most recent.
3. The last 5 Motor Errors, starting with the most recent.
4. The last 5 Product Fall Errors, starting with the most recent.
5. The last 5 Health Errors.
6. The last 5 MIS Resets.
7. The last 5 Time/Date sets.
8. The last 5 Price Settings.
9. The last 5 Power Outages.
10. The last 5 Defrost Events.

◆ **The chime will sound 3 times when there are no more items to display.**

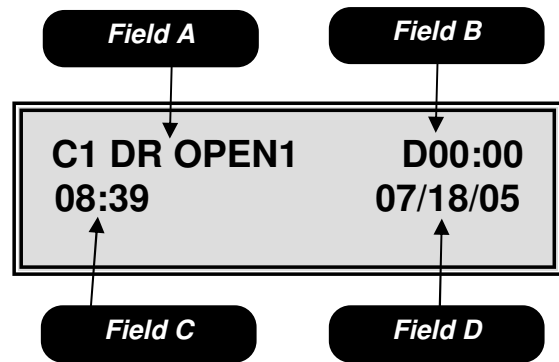

### **Mode 82 – Service History**

**Field A** is the event field.

**Field B** is the duration or selection field.

**Field C** is the time field.

**Field D** is date field.

# Programming

## Mode 83 – Temperature Log

Mode 83 is used to view the temperature log. To access this mode, press **83** on the numeric keypad.

Upon entering the temperature log mode, the display will show the current temperature. Field A shows the cabinet and zone the data is referencing (in this example C1L is the lower zone of a refrigerated machine). Field B is the total minutes since the temperature was last taken. Field C shows the temperature. Field D shows the status of the refrigeration unit at the time the temperature was taken. See the list below for the available options for Field D.

### Available Options

- R** – Refrigeration was on.
- D** – Defrost was on.
- O** – Refrigeration was off.

Use the ◀ key to view the previous temperature samples which have been taken in 1 minute intervals. When the last sample is reached the display will show 'NO MORE TEMPS' in the first line and Field E will scroll the message "TO CLEAR TEMPS PUSH # THEN \* TO RUN REFRIDGERATION TEST PUSH 1". To clear the temperature log press # then \*. To run the refrigeration test push the **1** key. The display will change to "REF TEST ACTIVE". Upon completion of the test the display will show either

"REFER TEST PASS" or "REFER TEST FAIL". To exit this mode, press the **C** key or press the Service Switch.

◆ **The chime will sound 3 times when there are no more items to display.**

## Mode 84 – Baffle Door Test

Mode 84 is used to test the baffle doors. To access this mode, press **84** on the numeric keypad.

In Field A use the # key to select which cabinet to perform the baffle test on. Press the **0** key to open the baffle door shown in Field B. Press the \* key to close the baffle door shown in Field C. To exit this mode, press the **C** key or press the Service Switch.

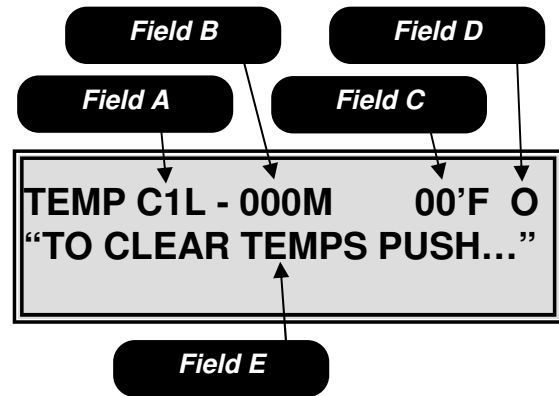

### Mode 83 – Temperature Log

**Field A** is the cabinet and zone indicator.

**Field B** is the total minutes since the temperature was last taken.

**Field C** is the temperature.

**Field D** is the status of the refrigeration unit at the time the temperature was recorded.

**Field E** is the scrolling instruction field.

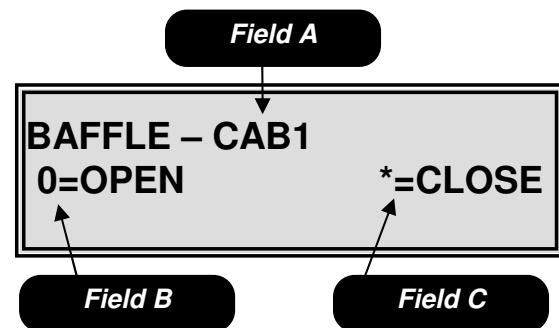

### Mode 84 – Baffle Door Test

**Field A** is the cabinet selection field.

**Field B** is the open baffle door key.

**Field C** is the close baffle door key.

# Programming

## Mode 85300 – Set Serial Number

Mode 85300 is used to set a serial number for retrieval during a print out or in the DEX data information. To access this mode, press **85300** on the numeric keypad.

Upon entering the set serial number mode, the display will show the current set serial number. Use the numeric key pad to set a serial number (up to 17 characters in length). When done editing, press **#** to save the number to memory. To exit this mode, press the **C** key or press the Service Switch.

◆ This field appears in a DEX file as ID101

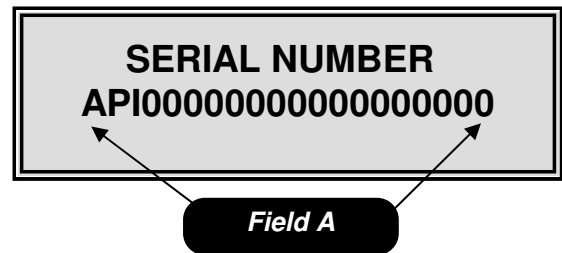

**Mode 85300 – Set Serial Number**  
*Field A* is the serial number set field.

## Mode 86200 – Set Machine ID

Mode 86200 is used to set a serial number for retrieval during a print out or in the DEX data information. To access this mode, press **86200** on the numeric keypad.

Upon entering the set machine ID mode, the display will show the machine ID number that is currently set. Use the numeric key pad to set a machine ID number up to 20 characters in length. When done editing, press the **#** to save the number to memory. To exit this mode, press the **C** key or press the Service Switch.

◆ This field appears in a DEX file as ID106

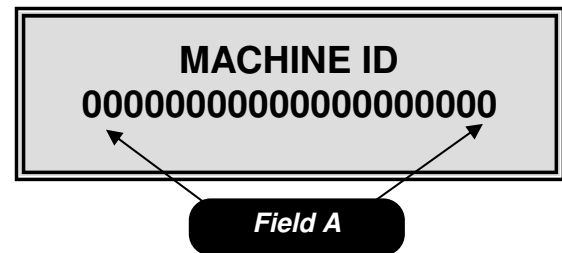

**Mode 86200 – Set Machine ID**  
*Field A* is the machine ID number set field.

## Mode 87400 – Set Location ID

Mode 87400 is used to set a location ID number for retrieval during a print out or in the DEX data information. To access this mode, press **87400** on the numeric keypad.

Upon entering the location ID mode, the display will show the current location ID number. Use the numeric key pad to set a location ID number up to 20 characters in length. When done editing, press the **#** to save the number to memory. To exit this mode, press the **C** key or press the Service Switch.

◆ This field appears in a DEX file as ID104



**Mode 87400 – Set Location ID**  
*Field A* is the location ID number set field.

## Programming

---

### Mode 88123456790 – Factory Test

Mode 88123456790 is used to run a factory test. To access this mode, press **88123456790** on the numeric keypad.

After entering the factory test mode, the machine will automatically test the first vend motor, you must then press the **#** key to advance to the next motor to be tested. If a vend motor is not present or is bad, the test will stop and the display will flash in Field B one of the following: MISSING, OVER CURRENT or TIMEOUT. To continue with the test press the **#** key. Once the test is complete all options and prices will be reset to factory defaults.

◆ **Using this mode on a machine full of product will cause one of each item to vend.**

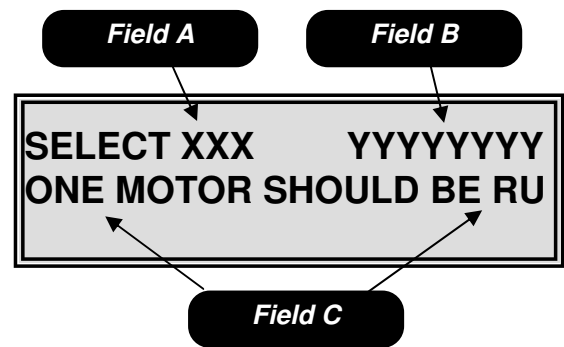

### **Mode 88123456790 – Factory Test**

**Field A** is the vend motor that is being tested.

**Field B** is the test information field.

**Field C** is the scrolling information field.

This page intentionally left blank.

# Parts

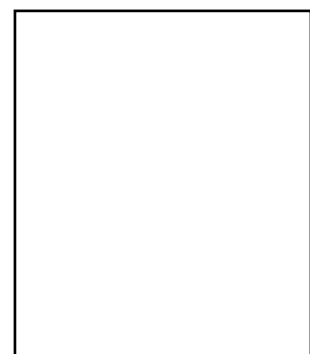
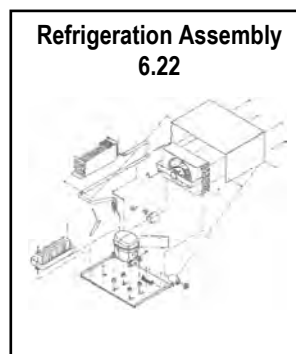
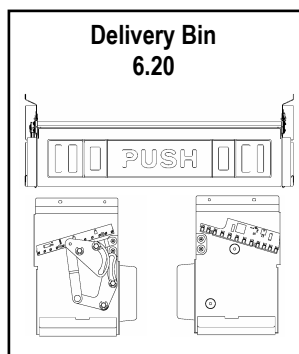
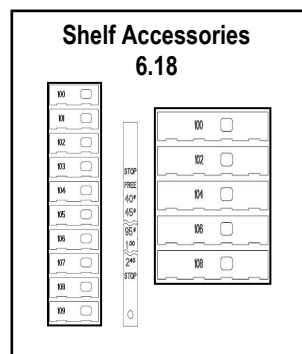
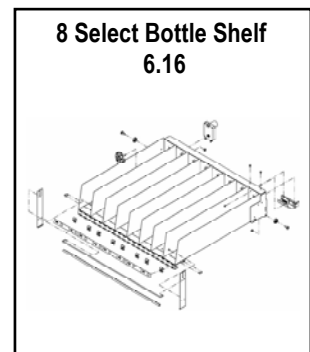
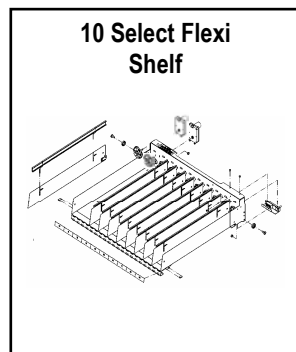
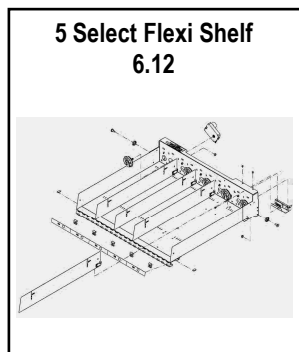
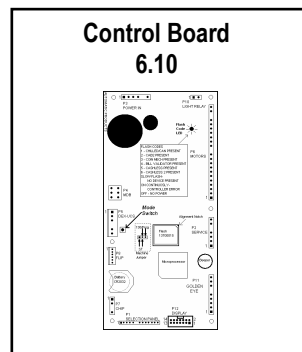
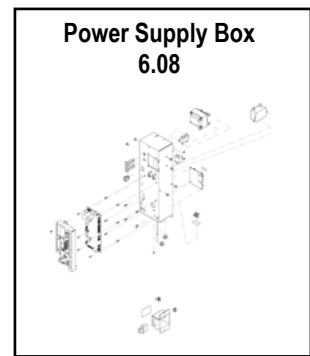
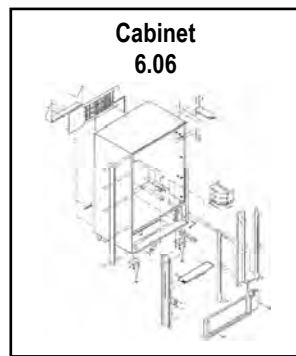
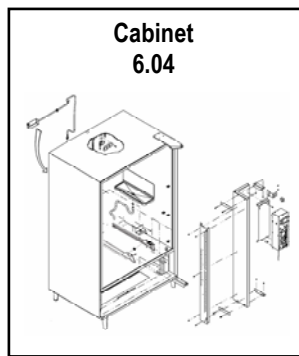
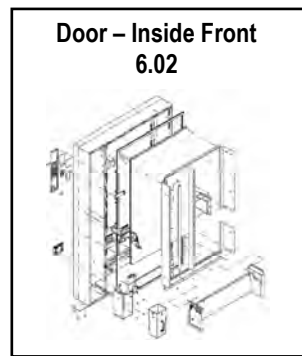

## HOW TO ORDER PARTS

1. Refer to the machine breakdown above. Each assembly breakdown contains an item description and page location in this parts manual.
2. Determine part number(s) needed by referring to drawing of part. Locate item number from drawing and refer to item number, part number and description.
3. Complete your parts order, double check part numbers and quantities. Include a call back number in the event there is a question regarding your order. Fax, email or mail your order to your authorized GPL distributor or GPL.

# Door Inside Front

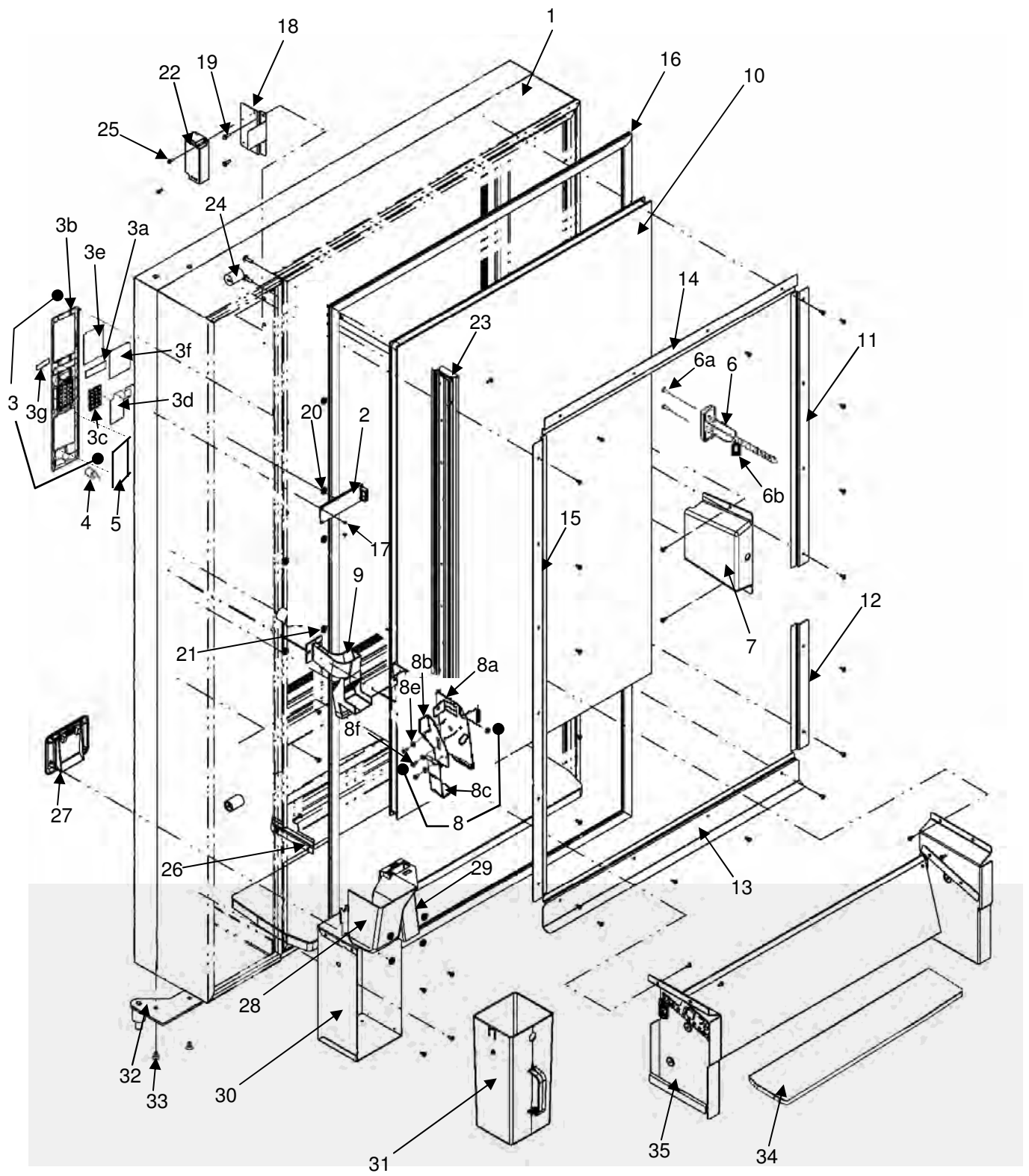



# Door Inside Front

Key	Description	Part Number
1	Door Weldment	65505010033
2	PCB Asm - 20 Char Display	13600032
3	Bezel, Selector Asm	16600378
3a	Display Window - ST	14400095
3b	Bezel, 15 Key select, ST Black	14400092
3c	Key Pad, 15 Key Numeric, Euro Gray	14400033-01
3d	Switch, Selection 15 Key	13800001
3e	Window, POS	14400094
3f	POS Insert PosiVend	80388666001
3g	GPL Logo Plate, Euro Gray	80182411001
4	Button, Coin Return Euro Gray	440289-5
5	Validator Filler Asm, Black	660580
6	T-Handle Asm	80152619011
6a	Bolt, 10-24 X 3/4 Carriage Bolt Zn	118-10-12
6b	Nut, 10-24 Keps Zn	438-10
7	Cover, Lock Handle	80182366001
8	Coin Return Asm, Complete	16600431
8a	Bracket, Coin Return	12000794-01
8b	Actuator, Coin Return	12000807
8c	Link, Coin Return	12000796-01
8d	Spring, Coin Return	400007
8e	Bushing	14400122
8f	Screw, 8-32 x 3/8 PN/NIBS HD	276-8R6
9	Coin Chute Asm	16600477
10	Window MANDR, Glass Pack, CMB 44.584 x 27.558 x .75	80510015001
	Window MANDR, Glass Pack, Heated 115v*	80510022011
	<b>Note: Replacement Glass Must be Hard Tempered</b>	
11	Clamp, Window, Locking Top Door	65505009003
12	Clamp, Window, Locking Bottom Door	65505011003
13	Clamp, Window, Bottom	65505007013
14	Clamp, Window, Top	65505008003
15	Clamp, Window, Hinge	65505039003
16	Gasket, Main Door	80182365001
17	Screw, 4-24 x 1/4 PH TYP AB	216-4R4
18	Bracket, Switch Actuator	65505015013
19	Screw, SL Hex Wash 8-32 x .500 Pluto	80030457001
20	Nut, 1/4 Self Threading, Pal	18443
21	Nut, 8-32 Keps Nut Zn	438-8
22	Asm, LED Lights Power Supply	80492752011
23	Asm, LED Light Strip	80492753001
24	Padding, Harness CMB	80182369001
25	Screw, 6-32 x 3/8 Phl Swg Frm	80030425001
26	Bracket, Bin Support, Left and Right	65505028013
27	Trim, Coin Cup, Black	16600403
28	Coin Return Cup	440413
29	Chute, Cash Box	440414
30	Bracket Asm, Cash Box Mounting	16600150
31	Cash Box, Plastic	14400047
32	Asm, Hinge Bottom	65505060003
33	Screw, 1/4-20 x 1/2 FL, Torx Tap	13100035-01
34	Pad, Delivery Port	80330187011
35	Asm, Delivery Port See Page 6.20 for itemized breakdown	65505070013
*	Optional Items	

# Cabinet

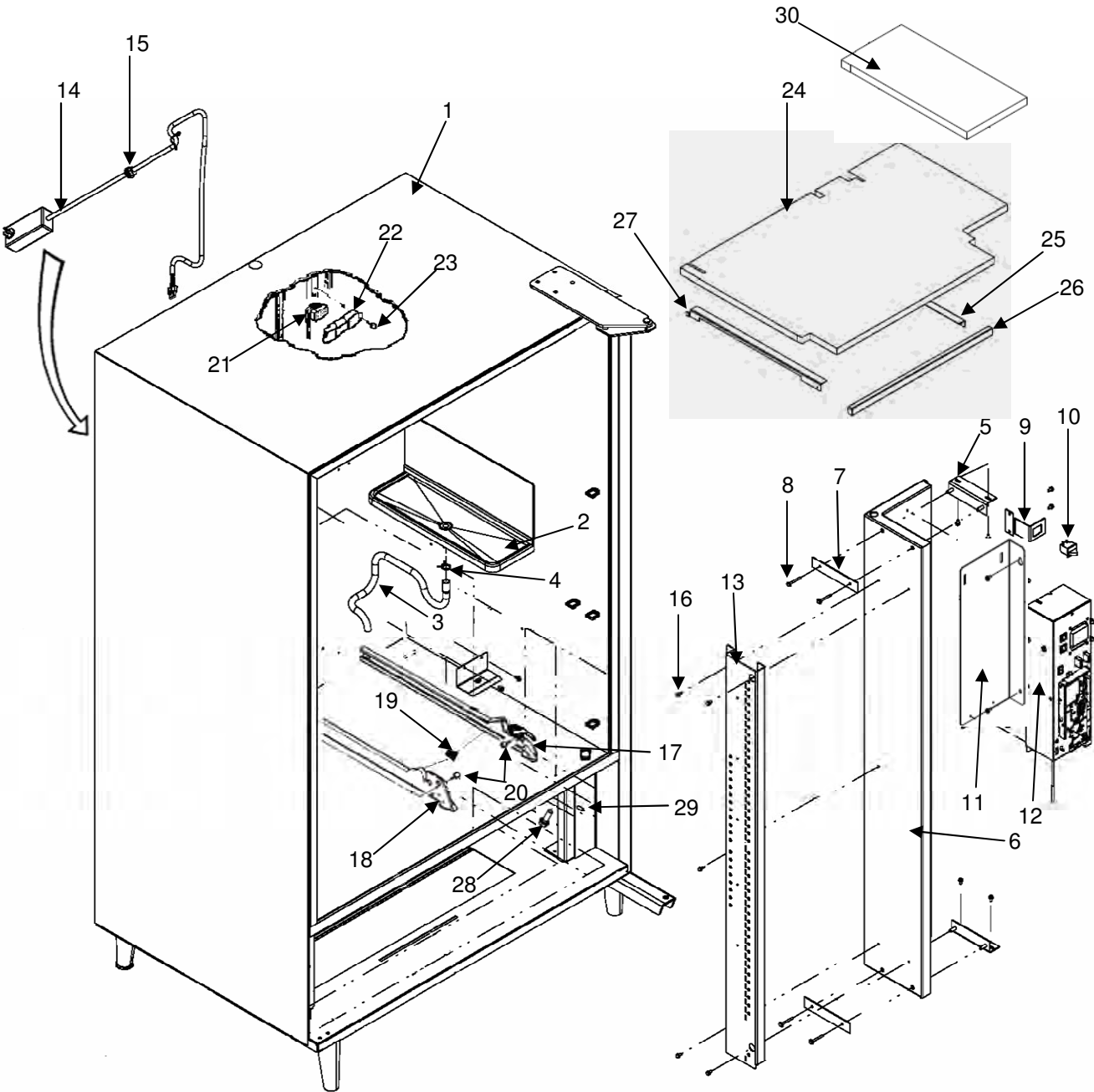

# Cabinet

---

Key	Description	Part Number
1	Cabinet Asm	
2	Asm, Evaporator Drain Pan	80182416001
3	Hose, Drain	80190492001
4	Clamp, Drain Hose	80090327001
5	Bracket, Foam Barrier	65507000013
6	Barrier, Foamed Panel Right	65502100033
7	Plate, Washer Barrier top & bottom	65507011003
8	Screw, 10-32 X 1.50 HH WA	53100025
9	Bracket, Door Switch	65507013013
10	Switch, Door	380258
	Harness, Door Switch	680632
11	Bracket, Power Dist Box	65503001013
12	Junction Box, See page 6.10 for itemized breakdown	
13	Brkt, Shelf Support Front Right	65507003053
	Brkt, Shelf Support Front Left (not shown)	65507001033
14	Cord, Line, 14-3 GFIC	80492726001
15	Bushing, Strain Relief SR-7W-2	380052-2
16	Screw, 10-24 X 3/8 Hex Wash Head Mach	80020275
17	Asm, Shelf Cabinet Track, Right	16400075
18	Asm, Shelf Cabinet Track, Left	16400077
19	Rail Insert, Left or Right	14400128
20	Screw, Undercut Flat Head for Shelf Rail	13100060
21	Asm Complete, Harness Cabinet Back`	16600456
	Harness Only, Cabinet Back	16800155
22	Mounting Bracket Only, Cab Back Harness	12000863
23	Screw, 8-32 X 3/8	13100064
24	Insulation, Shelf	80130832011
25	Bracket, Insulated Shelf, Right	65507024013
26	Bracket, Insulation, Front	65507023003
27	Bracket, Insulated Shelf, Left	65507025013
28	Screw, R, 1/4-20 x .75 HWH DLW	80030531001
29	Standoff, 1/4-20 THD x 1.50 LG	80190498001
30	Seal, Barrier CMB	80130839001

# Cabinet

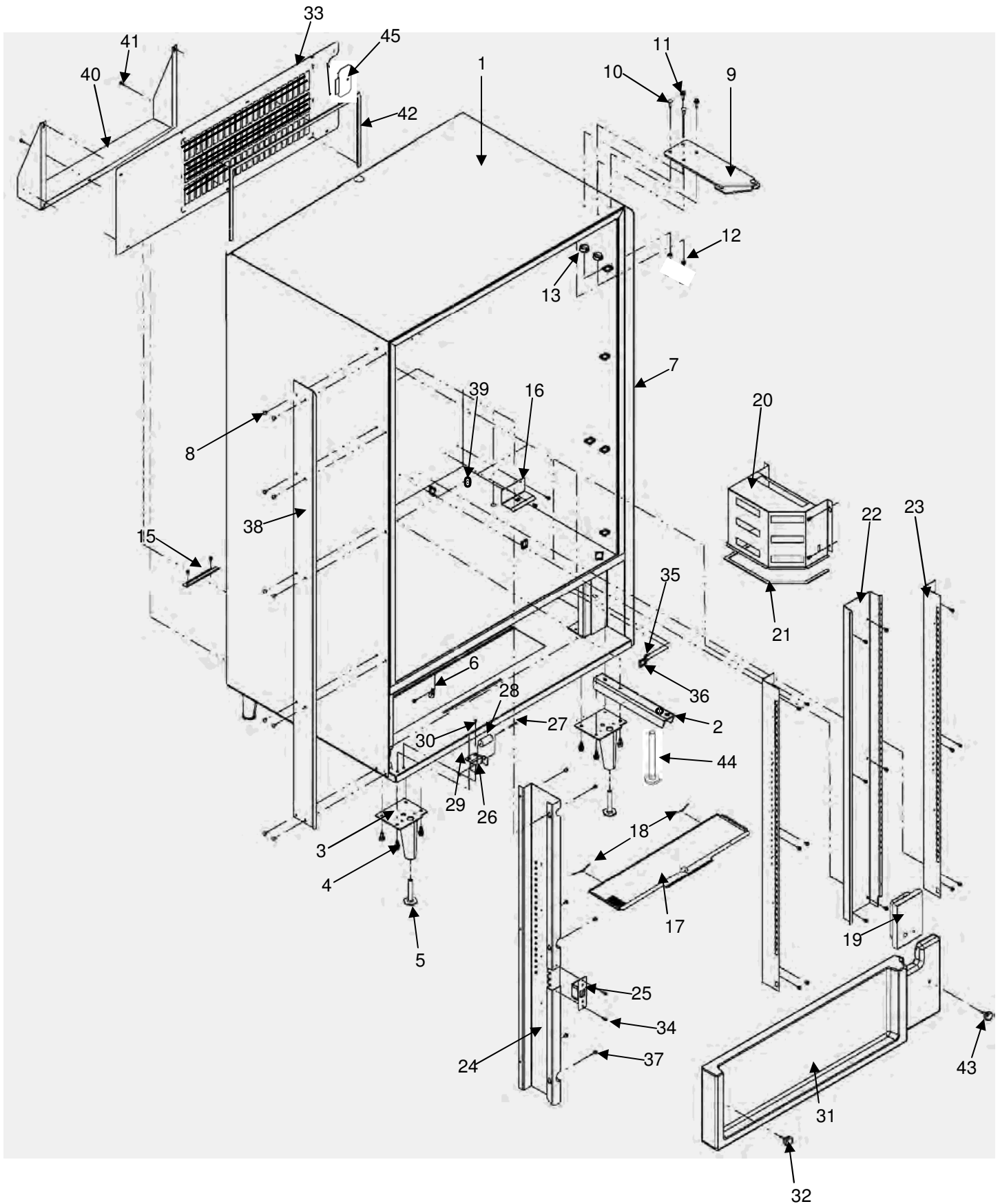

# Cabinet

Key	Description	Part Number
1	Asm, Cabinet Shell	
2	Hinge, Bottom Bracket	65500370003
3	Leg, Asm Front and Rear	600195
4	Screw, Hex 5/16-18 X 3/4	420187
5	Leg Leveler	300103
6	Clamp, Cable 9/16	90090227001
7	Panel, Vandal RT	65506002003
8	Rivet, Lrg Flange Head .125 x .313 Long	80110085001
9	Hinge, Asm, Top MNDR w/pin	65505050003
10	Bolt, Carriage, 1/4-20 UNC 2A	80020247011
11	Screw, S.T. 1/4-20 X 1	80030426001
12	Nut, KEPS 1/4-20	80080157001
13	Plug, Hole 1-1/8 Black	80181969001
14		
15	Bracket, Refrigeration Rear	65504008023
16	Bracket, Evaporator Mounting	65504001003
17	Screen, Vent .125 Perf Base	12000401
18	Spring, Vent Screen	460704
19	Gasket, Polyurethane Foam	80330182021
20	Duct, Refrigeration, Short	65506004003
21	Gasket, Air Duct	80200162001
22	Channel, Rear	65507004023
23	Brkt, Shelf Support Rear	65507002023
24	Brkt, Shelf Support Front Left	65507001003
NS	Brkt, Shelf Support Front Right (not shown)	65507003053
25	Asm, Receptacle Door Lock	65507010013
26	Bracket, Roller	65507012023
	Screw, Phillips Pan Head 10-32 x 1/2	80030413001
27	Pin, Roller	80050378001
28	Roller, Main Door	90180620001
29	Nut, Push Retaining	90090090001
30	Screw, Phillips Pan Head 10-32 x 1/2	80030413001
31	Panel, Foamed Barrier Bottom	65502090033
32	Knob, Pull	80152620001
33	Asm Screen Ingress CMB	65500360013
34	Screw, SL HEX Wash 8-32 X .500	
35	Screw, 8-32 X 1/2 HH ZP F SD WA	13100034
36	Wire Saddle, Locking Top Large	13100062
37	Screw, 10-24 X 3/8 SL HXWSH TYPF	80030496001
38	Panel, Vandal Left	65506003003
39	Clamp, Split Cable	13100071
40	Deflector, Air Rear	65507026013
41	Screw, 8-18 x .50 Unslot HWH Tek	80030451001
42	Gasket, Ingress	80330188001
43	Knob, Barrier Mounting	80152621001
44	Leveler, R 5/8-11 x 6.125 LG	80050410001
45	Cover, Strain Relief	202442-1
46	Harness –Board/light (Not shown)	80492739041

# Power Supply Box

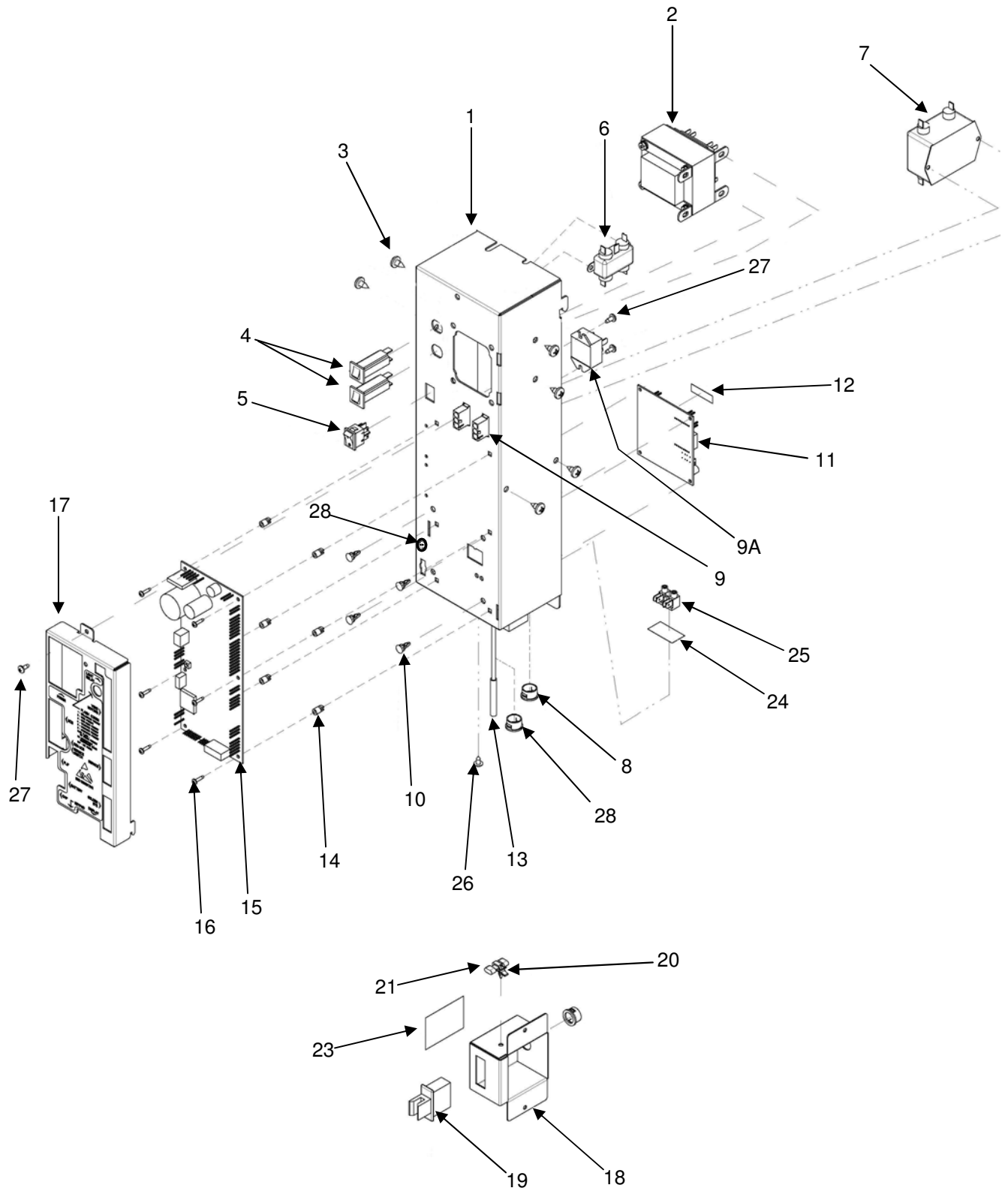

# Power Supply Box

---

Key	Description	120V USA	230V Export
1	Power Box assembly, Without Control Board	65500020013	65500010013
	Junction Box Weldment ST/130	12000800	12000800
2	Transformer 120v/230v ST	13900006	13900006
3	Screw, Pan Head, 1/4 x 1/2	216-41R8	216-41R8
4	Circuit Breaker 3 Amp	380241	380241
5	Switch Rocker	380243	380243
6	Filter-Light	380303	380303
7	RFI Filter-Line	380304	380304
8	Snap Bushing 1/2 Hole	420040-2	420040-2
9	Harness Junction Box	16800139	16800144
9A	Light Relay	16700030	16700030
9B	Harness, Light Extension, Power box to Door (included in part #80492739)		
10	Circuit Board Standoff	17100002	17100002
11	Asm, Circuit Board, Dual Temp	80492751011	80492751011
11A	Chiller Board to MDB harness	680659-1	680659-1
12	Warranty Label		
13	Temperature Probe	13600001-02	13600001-02
14	Standoff Circuit Board 1/4"	17100003	17100003
15	ST Control Board	13600024	13600024
16	Screw, 8-32 x 3/8 Pan Head	276-8R6	276-8R6
17	Control Board Cover Asm ST	16600386	16600386
18	Door Switch Box		12000122
19	Door Switch, Foreign C.T.		380262
20	Wire Saddle Side Entry		380321
21	Cheat Interlock Tool		380263
22	Cable Tie (Not Shown)		380078
23	Decal Voltage Disconnect		460642
24	Mylar Insulation-Contactor		440065
25	Terminal Block		380285
26	Screw, #8x3/8 Pan Head		210-8R6
27	Screw, Pan Head #6 X 1/2	218-6R8	218-6R8
28	Harness DEX/UCS Chassis Mount	16800044	16800044
29	Dome Plug 5/8 Hole (Not Shown)	420040-1	420040-1
30*	Harness Touch Memory	16800013	16800013
*	Optional items		

# Control Board

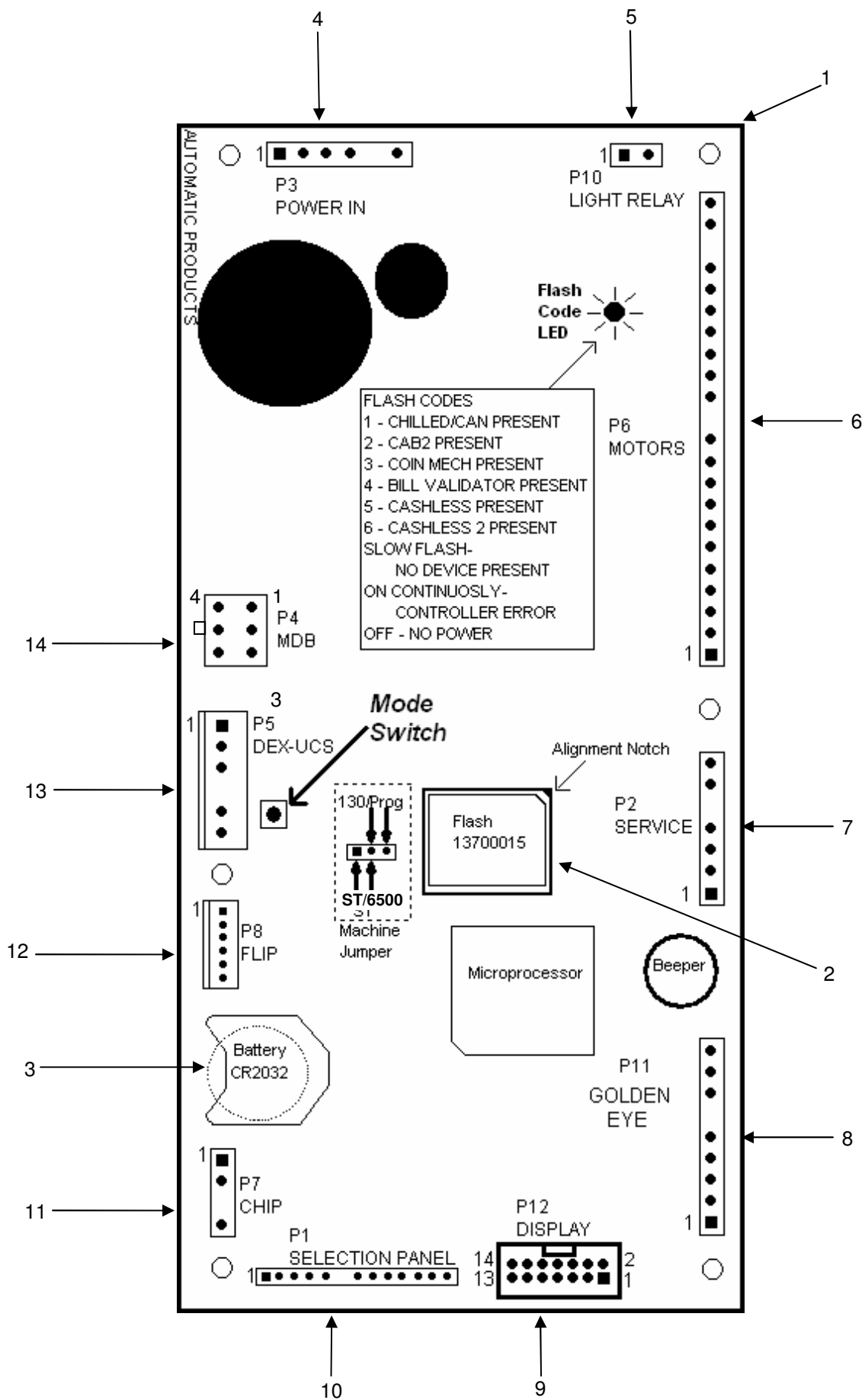



# Control Board

Key	Description	Part Number
1	Control Board.	13600024
2	Flash Memory Chip.	13700015
3	Battery CR2032. 3 Volt (available locally).	17100007
4	Power Box Harness	See page 6.08
5	Power Box Harness	See page 6.08
6	Cabinet Back Harness, Assembly Complete,	16600456
7	Harness, Door Switch	680632
8	Display/PV/Keypad/MDB Harness, Assembly Complete.	80492739041
9	Display/PV/Keypad/MDB Harness, Assembly Complete.	80492739041
10	Display/PV/Keypad/MDB Harness, Assembly Complete.	80492739041
11	Touch Memory Harness	16800013
12		
13	DEX/UCS Harness Assembly, Chassis Mount.	16800044
	DEX/UCS Harness Assembly, Loose	680509
14	Display/PV/Keypad/MDB Harness, Assembly Complete.	80492739041

## Fusion Cabinet Back Harness Color Code Chart

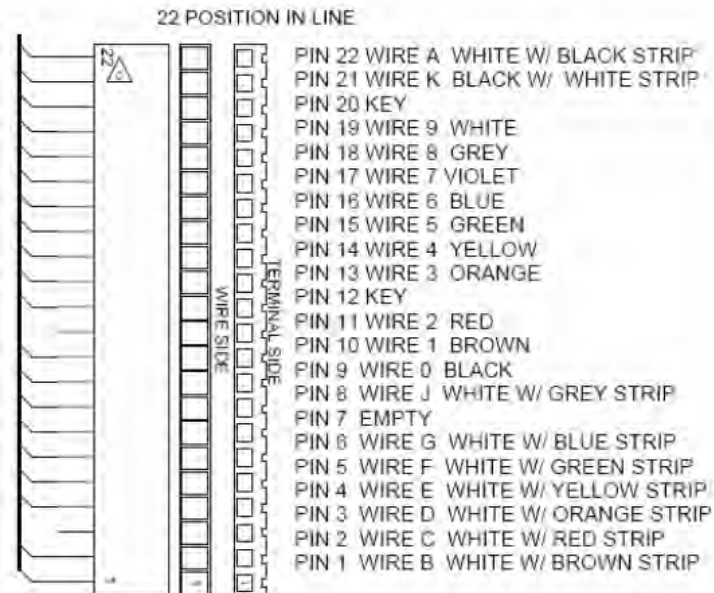

#	Row	Column
	<i>Base color/Stripe color</i>	<i>Solid Color</i>
0	White/Black	Black
1	White/Brown	Brown
2	White/Red	Red
3	White/Orange	Orange
4	White/Yellow	Yellow
5	White/Green	Green
6	White/Blue	Blue
7	White/Grey	Purple
8	Black/White	Grey
9		White

# 5 Selection Flexi Shelf

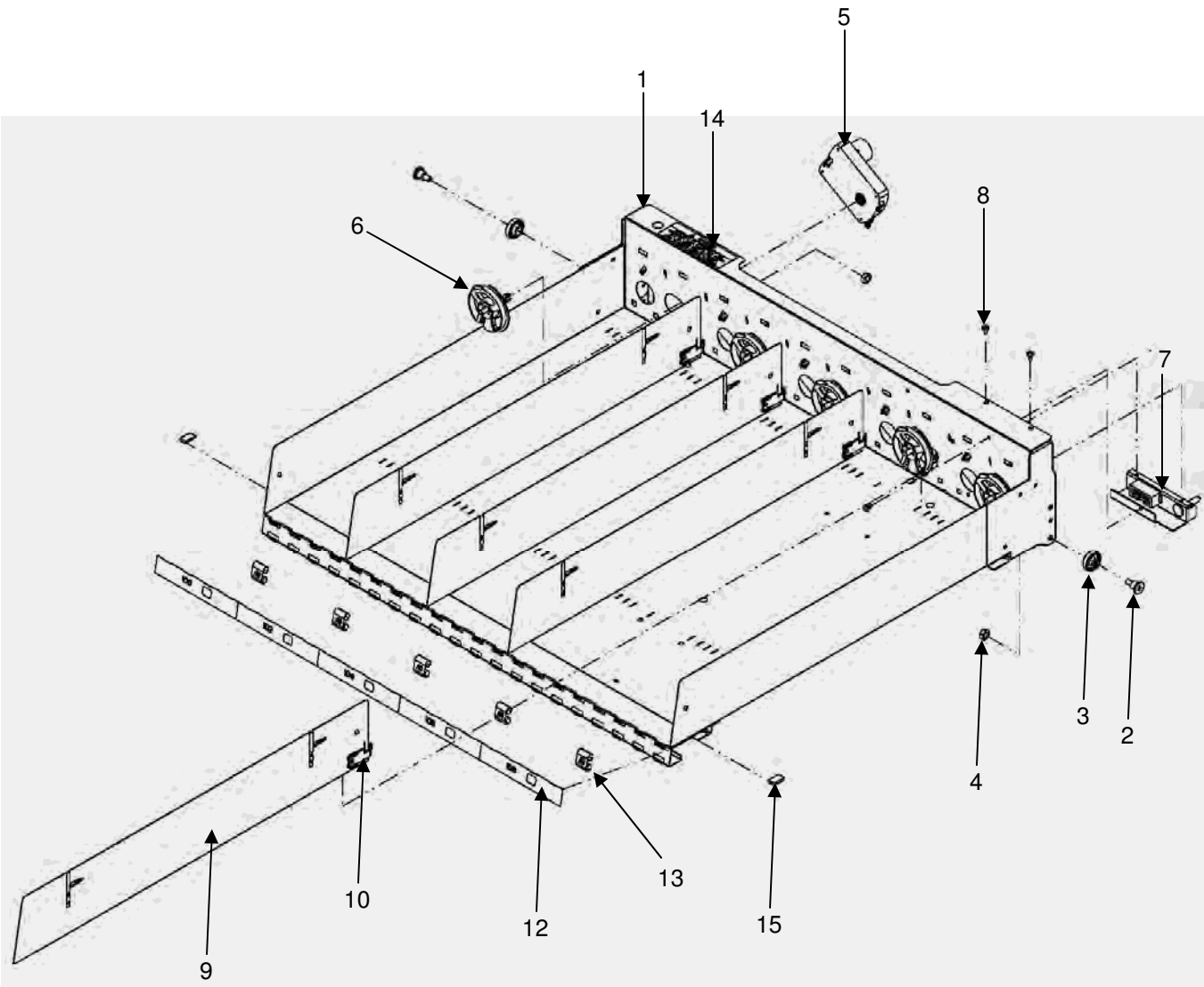

## 5 Selection Flexi Shelf

---

Key	Description	Part Number
1	Assembly Complete, 5 Select Flexi Shelf w/single blue/white motors (cw) No Spirals	65507050003
	Flexi Shelf, Weldement only, No Dividers	16000398
2	Screw, Shelf Roller.	300203
3	Shelf Roller	440362
4	Nut, keps (1/4 x 28)	437-41
5	Shelf Motor, CW, (Blue/white)	360275
6	Spiral Retainer, White, right Hand (RH)	440405
7	Assembly, complete. Harness with Bracket.	660435-8
	Harness only, 10 Selections	16800050
8	Screw, Ph. T-23 (8-32 x 5/16)	276-8R5
9	Assembly, Shelf Spacer	16600416
10	Spring Only, Shelf Spacer	14400116
11	Extension, Shelf Spacer (not shown)	202770
12	Selection tabs, Pastry, see page 6.18 for itemized breakdown	
13	Price tabs. Scroll from 40 cents to \$2.40	17400153
14	Decal, Convertible Shelf Caution	460494
15	Cap, Protective Shelf Tab	14400132

# 10 Selection Flexi Shelf

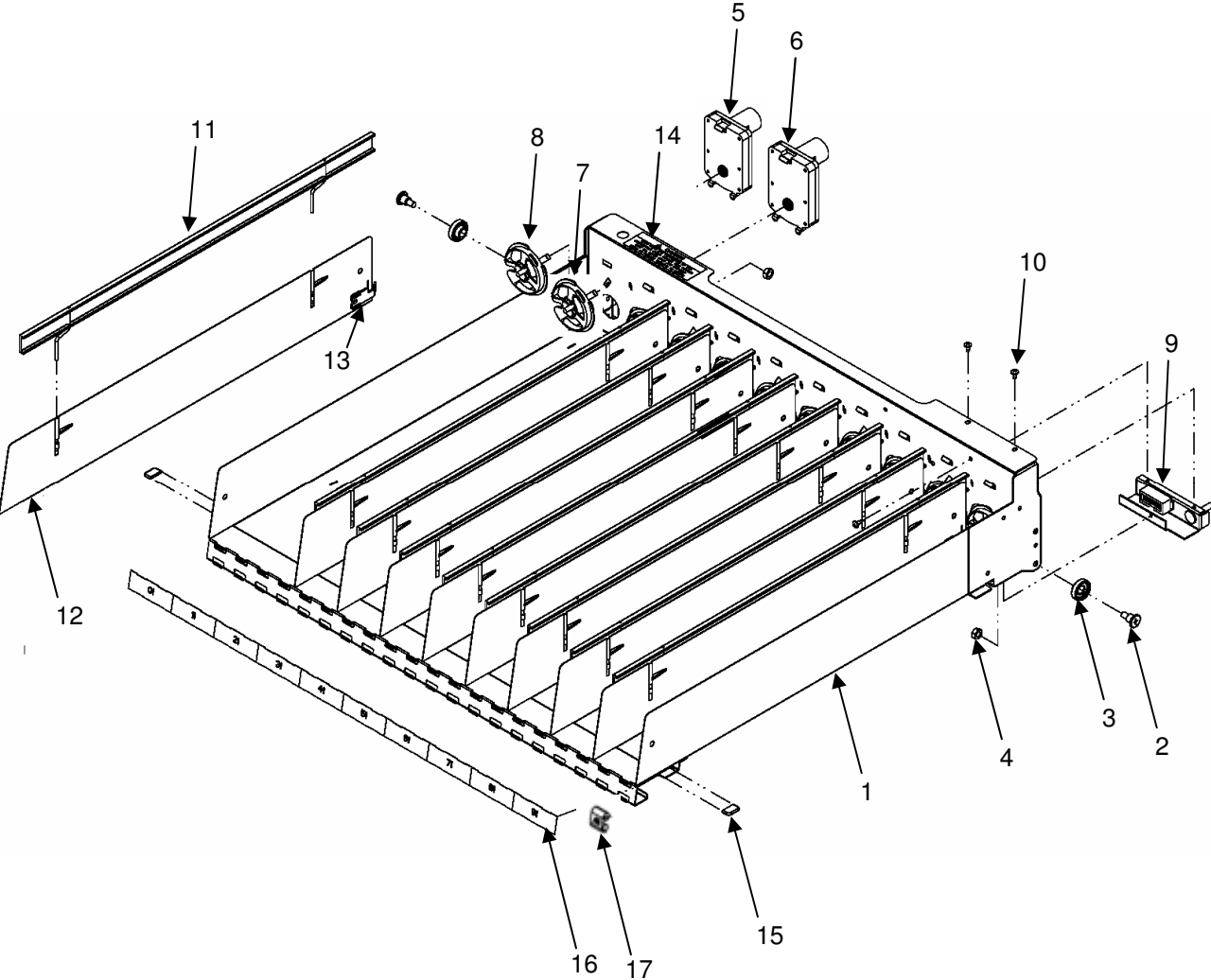

## 10 Selection Flexi Shelf

---

Key	Description	Part Number
1	Flexi-Shelf Complete, 10 Select Flexi Shelf, w/o spirals	65507080003
	Flexi-Shelf, Weldment Only, No Dividers	16000398
2	Screw, Shelf Roller	300203
3	Shelf Roller	440362
4	Nut, keps (1/4x28)	437-41
5	Vend Motor Complete, Counter Clockwise ccw (blue/gray)	360276
6	Vend Motor Complete, Clockwise cw (blue/white)	360275
7	Spiral retainer. White, Right Hand (RH)	440405
8	Spiral Retainer, Gray, Left Hand (LH)	440406
9	Assembly, Complete. Harness with Bracket	660435-8
	Harness Only, 10 Selections	16800050
10	Screw, PH.T-23 (8-32x5/16)	276-8R5
11	Assembly, Slide	16600389
12	Assembly, Shelf Spacer	16600416
13	Spring Only, Shelf Spacer	14400116
14	Decal, Convertible shelf	460494
15	Protective Cap, Shelf Tab	14400132
16	Selection tabs, 10 Item, see page 6.18 for itemized breakdown	
17	Price tabs. Scroll from 40 Cents to \$2.40	17400153
NS	Product Pusher, Right Hand, White	440141-1
NS	Product Pusher, Left Hand, Black	440215

# 8 Select Bottle Shelf

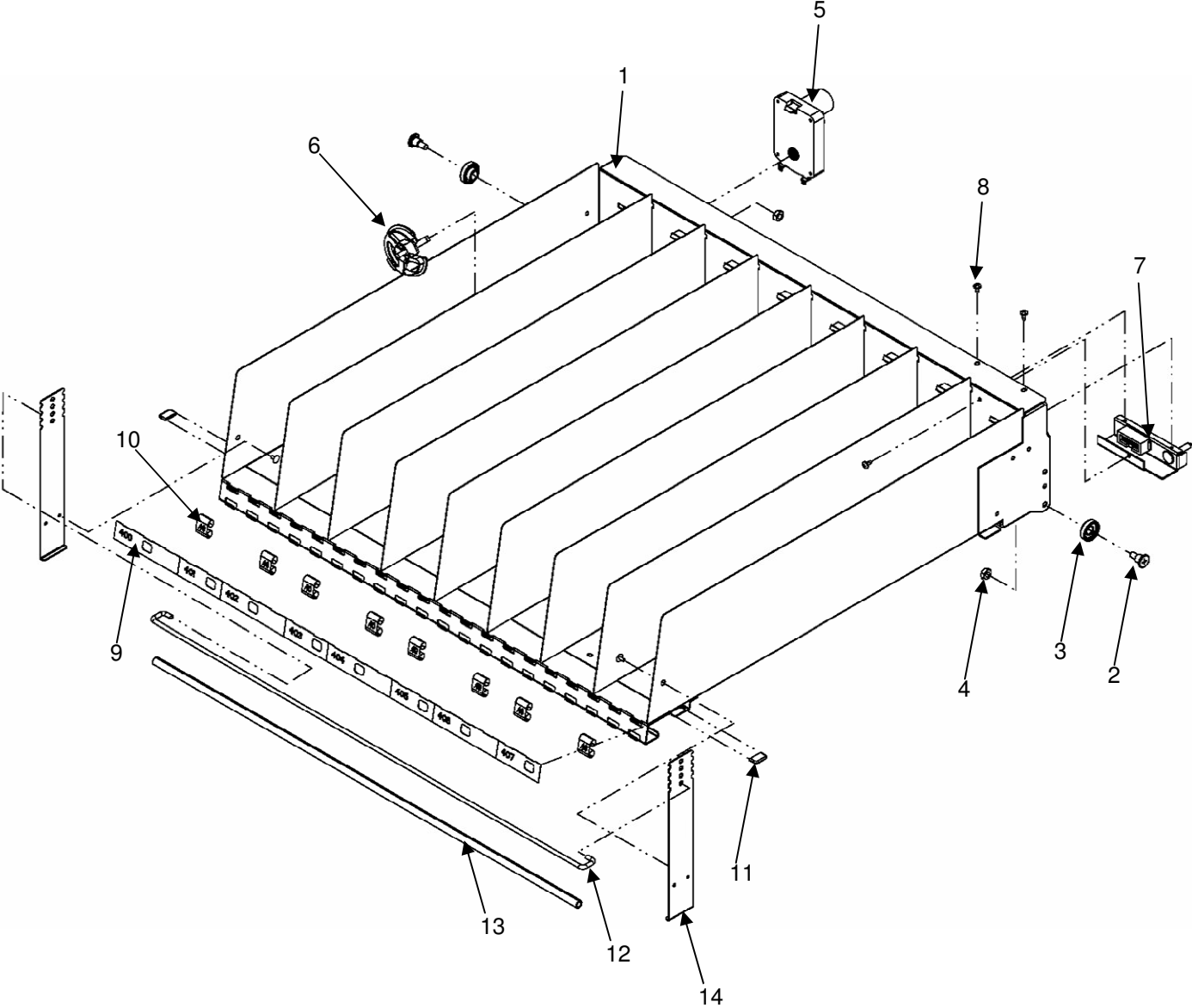

## 8 Select Bottle Shelf

---

Key	Description	Part Number
1	Assembly, complete, 8 Select Bottle Shelf w/single blue/white Motors (cw) No Spirals	65507030003
	Bottle Shelf, Weldment Only	65507040003
2	Screw, Shelf Roller.	300203
3	Shelf Roller	440362
4	Nut, keps (1/4 x 28)	437-41
5	Shelf Motor, CW, (Blue/white)	360275
6	Spiral Retainer, White, Right Hand (RH)	440405
7	Assembly, Complete, Harness with Bracket.	660435-8
	Harness only, 10 Selections	16800050
8	Screw, Ph. T-23 (8-32 x 5/16)	276-8R5
9	Selection Tabs, 8 Select, See Page 6.18 for Itemized Breakdown	
10	Price tabs. Scroll from 40 cents to \$2.40	17400153
11	Cap, Protective Shelf Tab	14400132
12	Rod, Bottle Catch	80140292001
13	Tubing, Bottle Catch	80320044011
14	Bracket, Bottle Catch	65507022003
NS	Spiral, 6 Count Bottle, Right hand (not shown)	400167-1

# Shelf Accessories

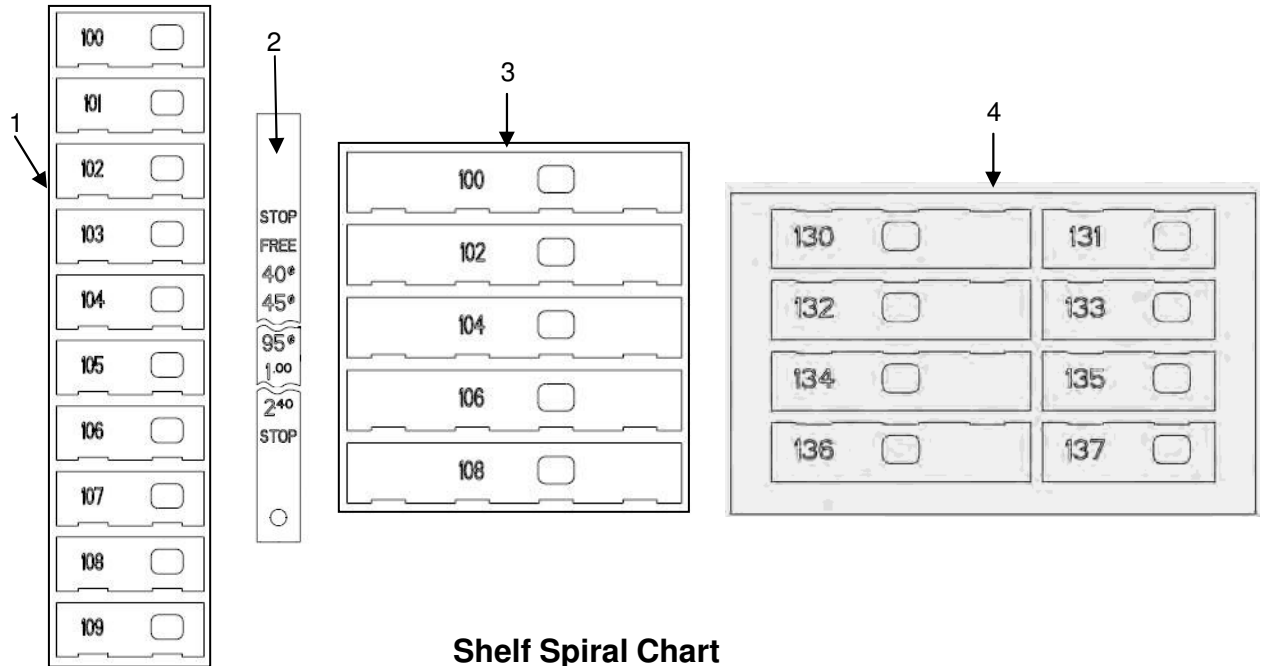

## Shelf Spiral Chart

Paired or Single Candy Spirals				
Spiral Depth	Left Hand Long Spiral Part #	Count	Right Hand Long Spiral Part #	Spiral Depth
4-1/8"		5 ct	14000004-01	4-1/8"
2-7/8"	14000003-01	6 ct	400167-1	2-7/8"
2-1/2"	400178-1	7 ct	400164-1	2-1/2"
1-15/16"	400179-1	9 ct	400166-1	1-15/16"
1-3/4"	400169-1	10 ct	400168-1	1-3/4"
1-1/2"	400170-1	12 ct	400120-1	1-1/2"
1-1/8"	400171-1	15 ct	400121-1	1-1/8"
15/16"	14000015	18 ct	400122-1	15/16"
11/16"	14000016	24 ct	400123-1	11/16"
1/2"		30 ct	400135-1	1/2"
3/16"		40 ct	400138-1	3/16"

Single Large Snack / Food Spirals		
Count	Part #	Depth
5 ct	14000002-01	4-1/8"
6 ct	400162-1	3-3/32"
7 ct	400153-1	2-21/32"
10 ct	400127-1	1-7/8"
12 ct	400128-1	1-9/16"
15 ct	400129-1	1-7/32"
18 ct	400163-1	1"
30 ct	400136-1	1/2"
40 ct	400137-1	5/16"

Bottle Spirals		
Count	Part #	Depth
6 ct	400167-1	2-7/8"



# Shelf Accessories

Key	Description	Part Number
1	Selection Tabs, Numbers 100-109 10 Select Shelf	17400158
	“ “ Numbers 110-119 “	17400159
	“ “ Numbers 120-129 “	17400160
	“ “ Numbers 130-139 “	17400161
	“ “ Numbers 140-149 “	17400162
	“ “ Numbers 150-159 “	17400163
	“ “ Numbers 160-169 “	17400164
2	Price Label, Self Coiling, \$.40 - \$2.40	17400153
	Price Label, Self Coiling, \$2.40 - \$4.35	80388674001
3	Selection Tabs, Numbers 100-109 5 Select Shelf	17400165
	“ “ Numbers 110-119 “	17400166
	“ “ Numbers 120-129 “	17400167
	“ “ Numbers 130-139 “	17400168
	“ “ Numbers 140-149 “	17400169
	“ “ Numbers 150-159 “	17400170
	“ “ Numbers 160-169 “	17400171
4	Selection Tabs, Number 130-137, 8 Select Bottle Shelf	80388573011
	“ “ Numbers 140-147 “	80388574011
	“ “ Numbers 150-157 “	80388575011
	“ “ Numbers 160-167 “	80388576011
NS	Product Pusher, Right Hand	440141-5
NS	Product Pusher, Left Hand	440215

## Product Rail Chart

**Can Rail - Low**

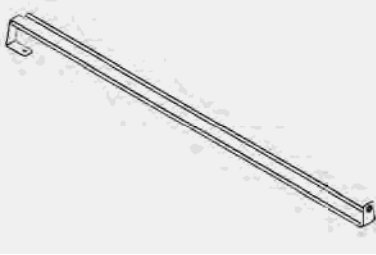

ST 1 & 5	12000822-01
ST 2, 3 & 4	12000822

**Half Cycle Rail**

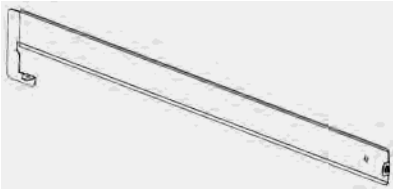

ST 1 & 5	12000823-01
ST 2, 3 & 4	12000823

**Can Rail - High**

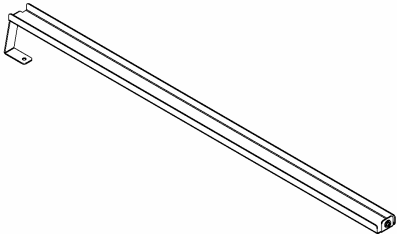

ST 1 & 5	12000824-01
ST 2, 3 & 4	12000824

**Candy Rail**

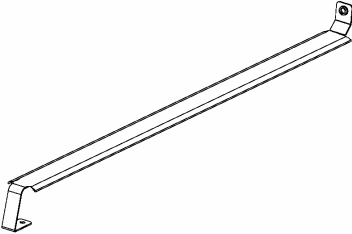

ST 1 & 5	16600449-01
ST 2, 3 & 4	16600449

**Pastry Rail**

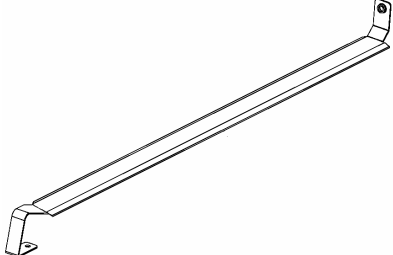

ST 1 & 5	16600451-01
ST 2, 3 & 4	16600451

**Small Product Rail**

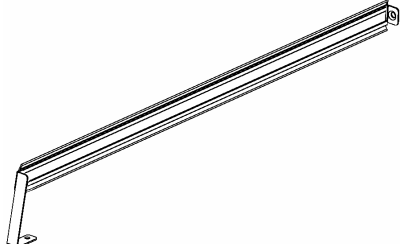

ST 1 & 5	16600452-01
ST 2, 3 & 4	16600452

# Delivery Bin

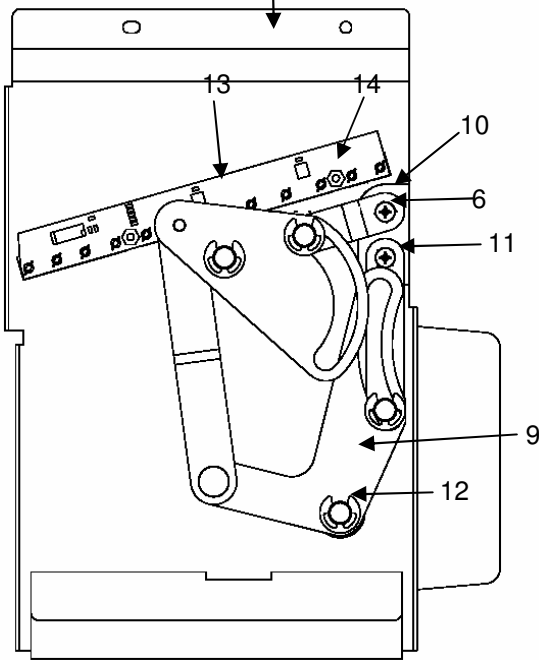
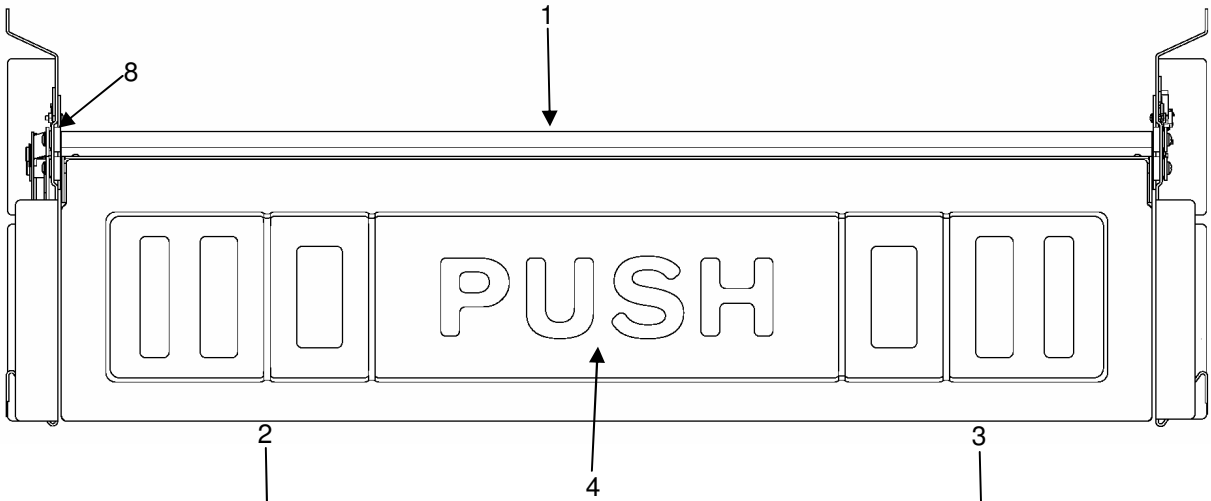
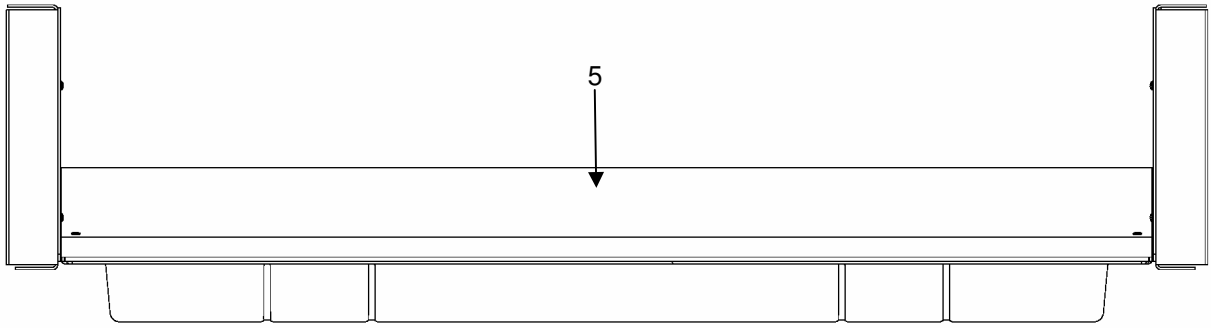

**Lock Side**

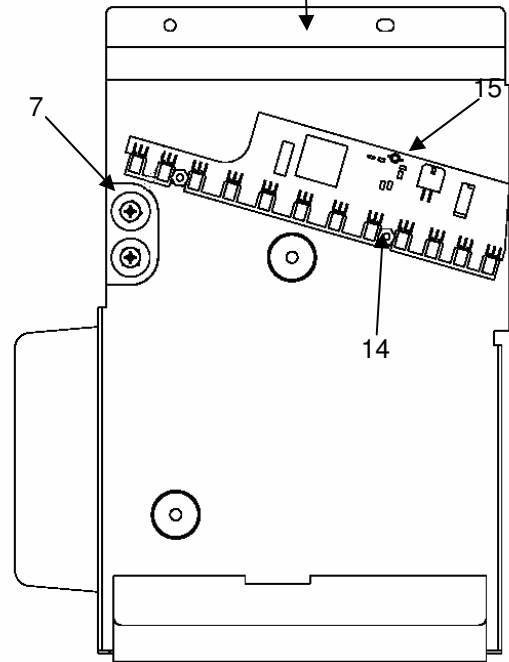

**Hinge Side**

# Delivery Bin

---

Key	Description	Part Number
1	Asm, Delivery Port Complete	65505070013
2	Asm Complete, Delivery Port, Lock Side	65505080013
	Mounting Plate Only	65505130013
3	Asm, Delivery Port, Hinge Side	65505090003
	Mounting Plate Only	65505023043
4	Asm, Delivery Door	65505150003
5	Asm, Security Plate	65505100003
6	Screw, 8-32 x 3/8 Pan HD Machine	116-8R6
7	Washer, Bin Door	420282
8	Bearing, Door (not shown)	440129
9	Asm, Drive Linkage	9332045
10	Inner Bin Door Driver	9332042
11	Bin Door Drive Arm	640097
12	Retaining Ring 3/8	751-37
13	PCB Asm, Hi Res PV Led (lock side)	13600022-01
	Lens, PosiVend, Lock & Hinge side (not shown)	14400101
	Insulator, PosiVend, Hinge side (not shown)	14400097
14	Nut, 4-40 Nylon	13100028
	Screw, 4-40 x 3/8 Pan Hd Machine (not shown)	116-4R6
15	PCB, Hi Res PV Sensor (hinge side)	13600020-01
	Lens, PosiVend, Lock & Hinge side (not shown)	14400101
	Insulator, PosiVend, Lock side (not shown)	14400096

# Refrigeration Assembly

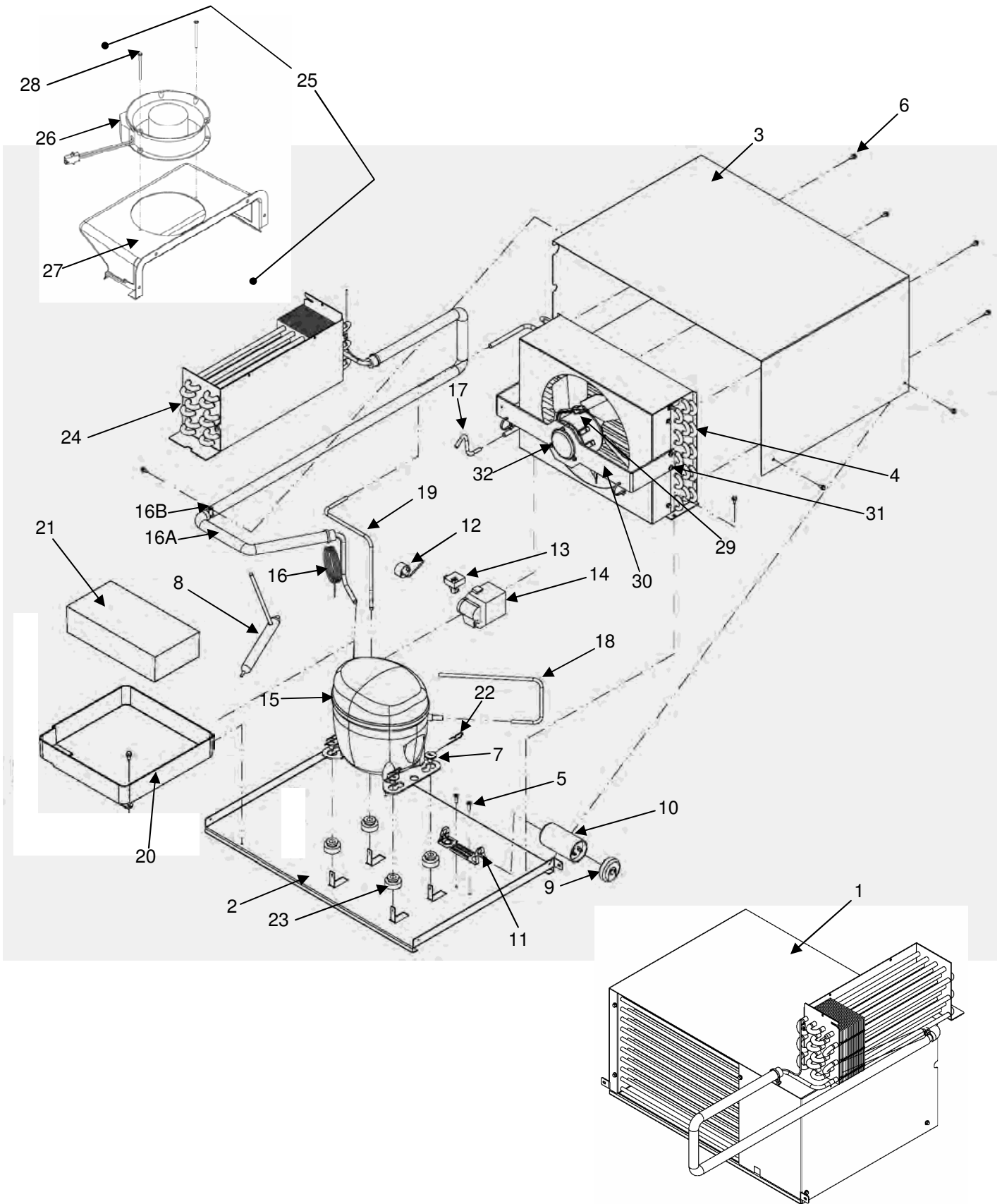

# Refrigeration Assembly

Key	Description	117V, 60 Hz Domestic	230V, 50 Hz Export
1	Refrigeration Asm, Complete	65504000023	
2	Base Plate, Refrigeration	65504003013	
3	Cover, Refrigeration	65504009023	
4	Condenser Asm, Complete w/fan	65504040013	
	Condenser, Only	80260075001	80250285001
	Shroud Only, Condenser	65504004013	
5	Screw, 10-32 X 1/2 TCS	80030433001	
6	Screw, Hex Washer HD 1/4 -20 X 3/8 Unslotted	80030438001	
7	Plug, Compressor Grommet		
8	Drier, .064 Extended Outlet, R134A Outlet, R134A	80240130011	
9	End Cap, Bottom Hole Capacitor #4, 5		
10	Capacitor, Start	80250221001	80240169001
11	Bracket, Capacitor	80250187001	
12	Overload, TI	80250210001	80240172001
13	Relay, TI	80250213001	80240170001
14	Cover, Embraco 1.355.504 (Short)	80250186001	80240173001
15	Compressor, 115/60, 1/3 HP	80250174001	
	Harness, Compressor (not shown)	80492740011	
16	Line Asm, Capillary / Suction		
16A	Tube, Insulation, 53 inches	90330083011	
16B	Clamp, Cable 5/16	90090227001	
17	Tube, Condenser Outlet		
18	Tube, Low Process		
19	Tube, Discharge		
20	Pan, Drain	80182412011	
21	Pad, Evaporation	14600026	
22	Clip, Spring	90090188001	
23	Grommet, Compressor	90200057001	
24	Asm, Evaporator Coil	65504050003	
25	Asm, Evaporator Fan	65504010003	
26	Motor, Evaporator Fan	80450173001	
27	Shroud, Evaporator Fan	80182367001	
28	Screw, 8-32 X 2.500 SL Hexwash Steel Zinc	80030524001	
29	Fan Asm, Condenser, Motor & Blade	65504070003	
	Motor Only, Condenser Fan	80450178001	
	Blade Only, Condenser Fan	80130833001	
	Silencer	80210045001	
	Nut, Speed 1/4-20 UNC	80080197001	
30	Bracket Only, Condenser	65504005003	
31	Screw, 10-32 x 1/2 Phillips Pan Head	80030413001	
32	Screw, 8-36 UNF x 3/8, HWH W/Serrations	80030527001	

**Note: Parts shown for identification without part numbers in columns are not sold separately.**

# Service

## GPL6500 Refrigeration unit removal instructions

- 1) Power off machine, disconnect plug from wall, disconnect the 4 pin connector from the bottom of the power box.

Note: **1** Indicates Instruction Step

- 2) Empty and remove second shelf up from the bottom of the machine.
- 3) Loosen and remove the 2 large thumbscrews holding the lower barrier in place. Set barrier and hardware aside.
- 4) Push back on the tab on the air inlet screen, and remove screen from machine.
- 5) Disconnect shelf harness from control board.
- 6) Remove large foam plug from bottom of foam barrier.
- 7) Reach between rails on right side of machine, and disconnect the 2 pin connector from the evaporator fan. Pull this harness out of the refrigerated compartment through the access hole.
- 8) Slide the silver temperature probe out of its mounting clamps, and pull completely out of the cabinet. Coil this harness carefully to ensure it does not get damaged during the removal process.
- 9) Undress the shelf harness and the compressor power harness from the clips on the right side wall.

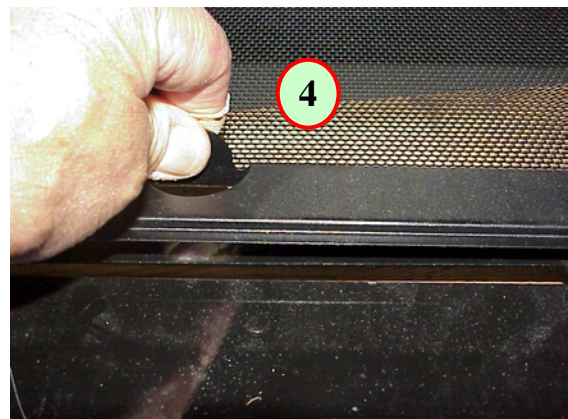
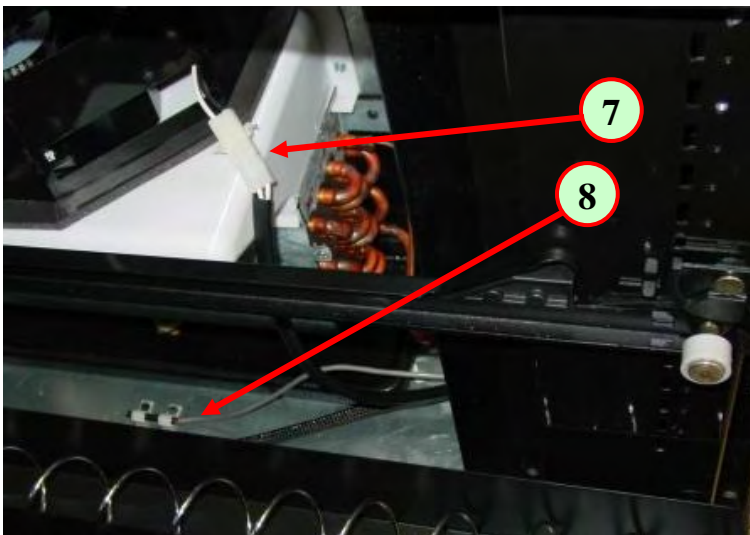
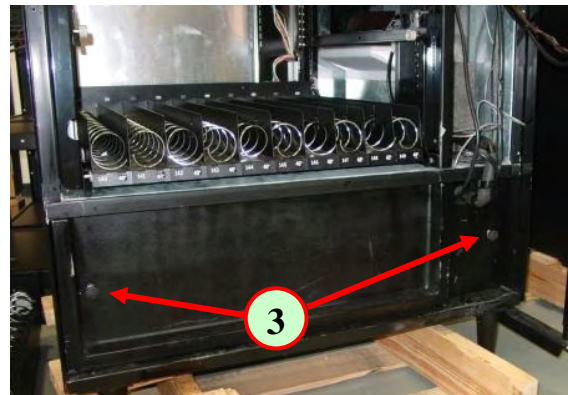
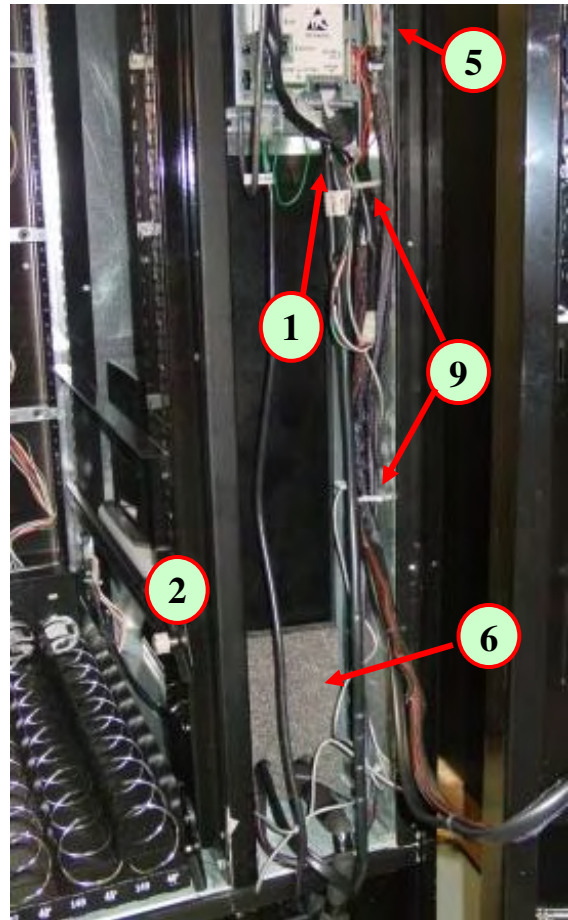

# Service

- 10) Cut or remove any tywraps securing the main power cord to the refrigeration tubing.
- 11) Pull the shelf harness into the cabinet and coil carefully on top of the bottom shelf.
- 12) Remove the 2 screws securing the compressor asm to the floor of the cabinet.
- 13) Remove the top center screw on the end of the evaporator coil.
- 14) Carefully slide the compressor asm forward, at the same time slide the evap coil forward off of its support brackets.
- 15) Continue sliding both parts forward until the evap coil has cleared the opening in the foam barrier.
- 16) Carefully support the unit (both the compressor and evaporator coil) until the unit is completely outside the machine.
- 17) Secure the evaporator coil to the side of the refrigeration unit cover for transport using the 2 screws provided.

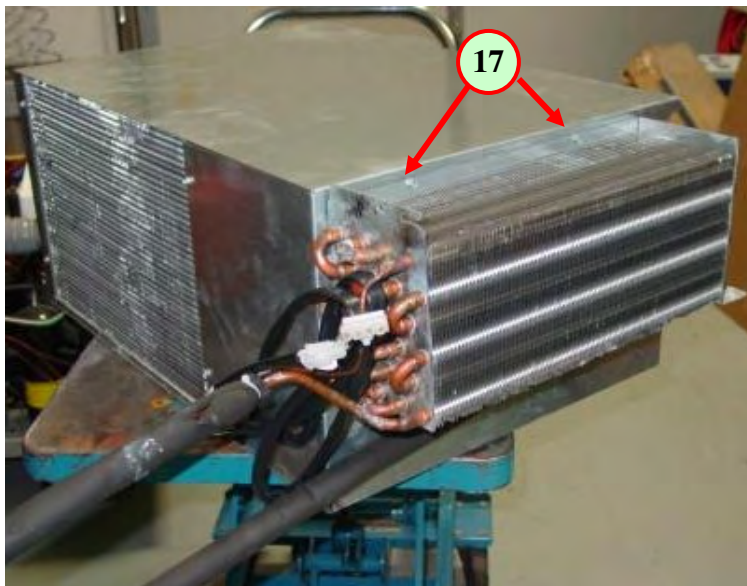
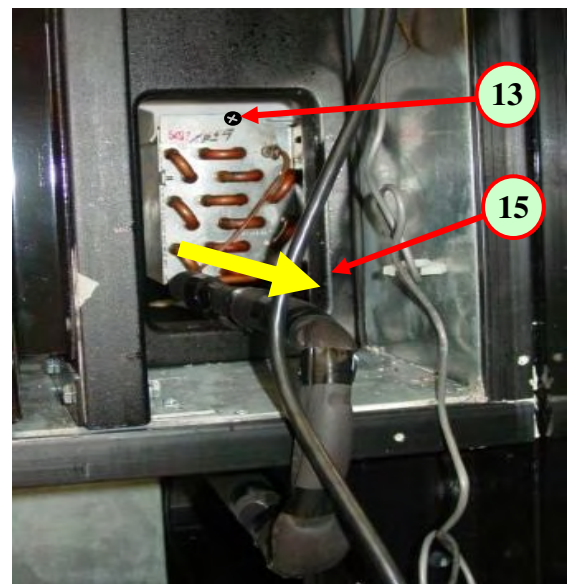
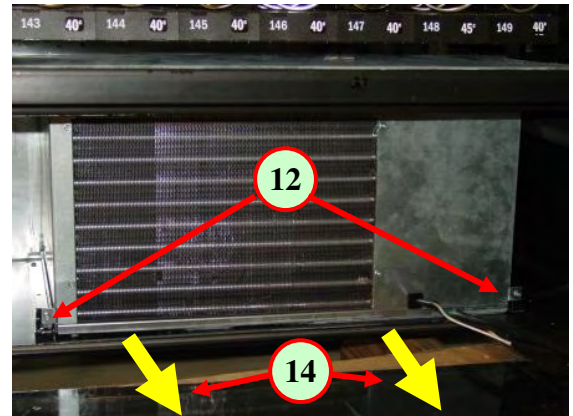
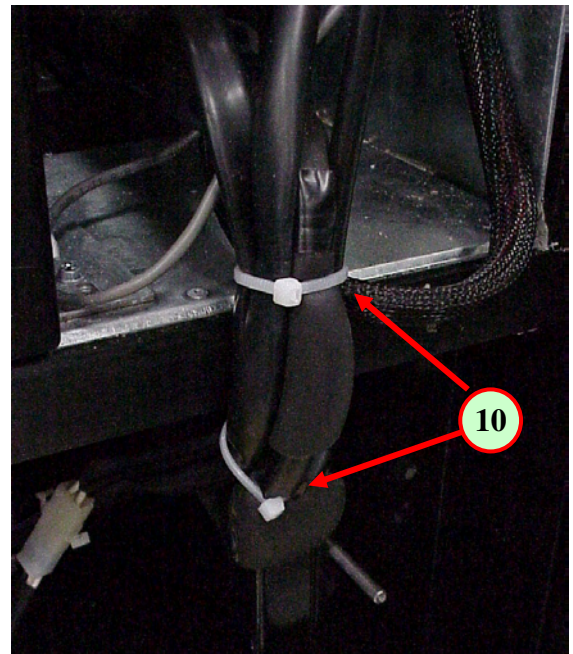

# Service

---

## Fusion Paired Motor Shelf Conversion Instructions

These instructions provide the steps to convert two candy selections on a paired motor candy shelf to a single dual spiral snack selection, or visa versa.

### Convert Two Candy Selections to One Snack

- 1) Remove product from 2 adjacent spirals – Left hand motor must be an even number.
- 2) Remove divider from between the 2 spirals.
- 3) Remove the selection number tabs from both selections
- 4) Remove one of the 2 scrolling price tabs rolls
- 5) Move the remaining scrolling price tab to position C on drawing below.
- 6) Store removed tabs and scrolling price roll in the service envelope, and retrieve the correctly numbered selection tab from the extras provided in the service envelope.
- 7) Install the new selection tab on the front of the shelf.
- 8) Count the number of spaces in each spiral to verify that they are the same. Change spiral if required.
- 9) Load product in selection.
- 10) Access Mode 23, and pair the motors
- 11) Access Mode 20, and set the new price, and adjust the scrolling price tab as required.
- 12) Test vend with money to ensure correct operation

### Convert One Snack to Two Candy Selections

- 1) Remove product from spirals.
- 2) Install divider between the 2 spirals, between positions B & C.
- 3) Remove the selection number tab from the selection.
- 4) Remove the scrolling price roll.
- 5) Locate the extra selection tabs and scrolling price rolls in the service envelope, and retrieve the correctly numbered selection tabs and a scrolling price roll from the service envelope.
- 6) Install the scrolling price rolls in positions B and D.
- 7) Install the two selection tabs on the front of the shelf in positions A, B and C, D
- 8) Load product in selections.
- 9) Access Mode 23, and disable the paired motors.
- 10) Access Mode 20, and set the new price for both selections, and adjust the scrolling price tabs as required.
- 11) Test vend with money to ensure correct operation

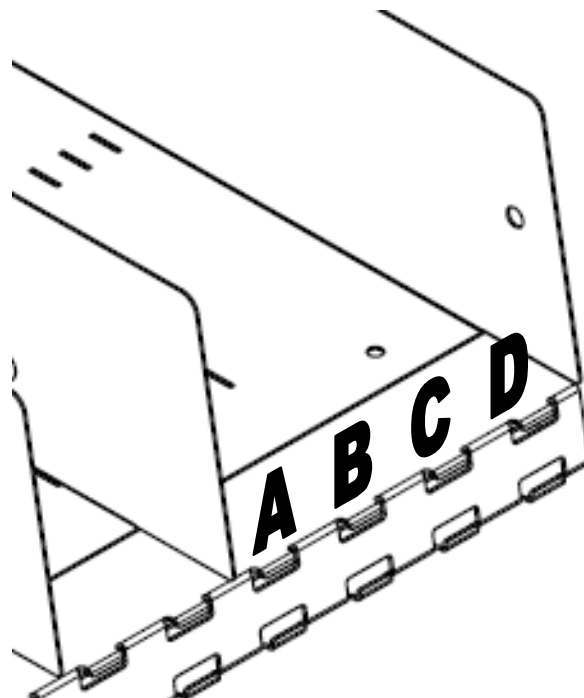



# Service



The Flexi Shelf has the ability to convert 3 candy selections into a single paired motor selection. The instructions to do this are below. When doing this conversion keep in mind the following 3 rules.

1. There must be a grey motor on the left and a white motor on the right.
2. The selection number used will be the lowest even number used in the pairing.
3. The wire number on the left motor must match the last digit of the selection number used.

## Convert Three Candy Selections to One Dual Selection

- 1) Remove shelf from the machine and place on a sturdy surface.
  - 2) Remove the product from 3 adjacent spirals.
  - 3) Remove the dividers from between the 3 spirals, dividers 2 & 3 in the drawing below.
  - 4) If the left most motor of the 3 has a white spiral retainer follow instructions 5 through 14 below. If the left most motor of the 3 has a grey spiral retainer follow instructions 15 through 24 below.
- |   |  |
|---|--|
| <ol style="list-style-type: none"><li>5) Remove the spirals and spiral retainers from motors A &amp; B in the drawing below.</li><li>6) Disconnect wires and remove the selection motor position A in the drawing below. Tape and secure these wires.</li><li>7) Relocate motor B to position A in the drawing below. Reinstall the grey spiral retainer on this motor</li><li>8) Reinstall spiral; count the number of spaces in each spiral to verify that they are the same. Change spiral if required.</li><li>9) Remove the selection number tabs in positions A &amp; C in the drawing below. Turn them around and reinstall them with the blank side out.</li><li>10) Set the 2 outer price scrolls in positions A &amp; C in the drawing below to the blank position. The blank position is located just before the word stop at the beginning of the scroll.</li><li>11) Load product in selection.</li><li>12) Access Mode 23, and pair the motors.</li><li>13) Access Mode 20, and set the new price, and adjust the scrolling price tab as required.</li><li>14) Test vend with money to ensure correct operation</li></ol> | <ol style="list-style-type: none"><li>15) Remove the spirals and spiral retainers from motors B &amp; C in the drawing below.</li><li>16) Disconnect wires and remove the selection motor from position C in the drawing below. Tape and secure these wires.</li><li>17) Relocate motor B to position C in the drawing below. Reinstall the white spiral retainer on this motor.</li><li>18) Reinstall spiral; count the number of spaces in each spiral to verify that they are the same. Change spiral if required.</li><li>19) Remove the selection number tabs in positions B &amp; C in the drawing below. Relocate the remaining selection tab from position A to position B in the drawing below. Turn the remaining 2 selections tabs around and reinstall them in positions A &amp; C with the blank side out.</li><li>20) Set the 2 outer price scrolls in positions A &amp; C in the drawing below to the blank position. The blank position is located just before the word stop at the beginning of the scroll.</li><li>21) Load product in selection.</li><li>22) Access Mode 23, and pair the motors.</li><li>23) Access Mode 20, and set the new price, and adjust the scrolling price tab as required.</li><li>24) Test vend with money to ensure correct operation</li></ol> |
|---|--|

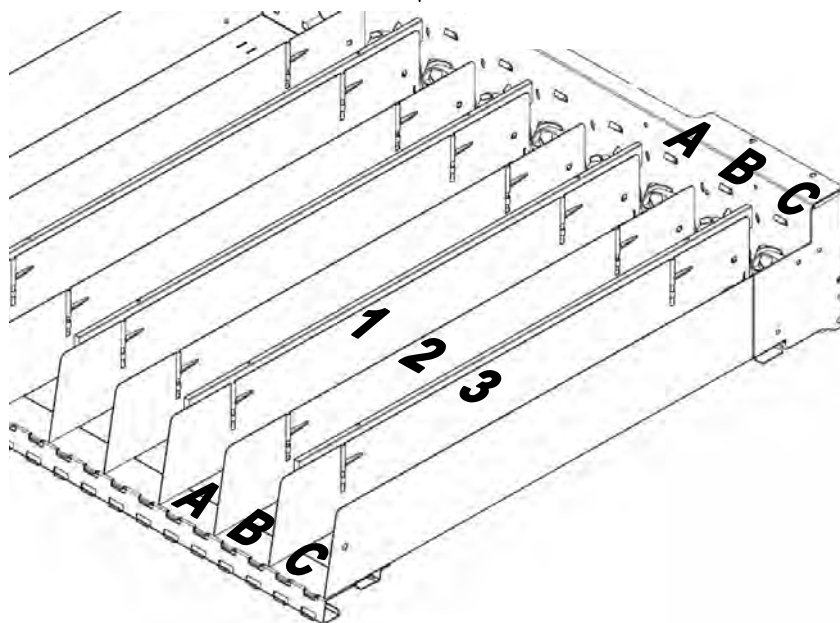

# Troubleshooting

## LCB BOARD CONNECTIONS

### P1 KEYPAD SWITCH LINES

1	Row 1
2	Row 2
3	Row 3
4	Row 4
5	Row 5
6	Key
7	Col 1
8	Col 2
9	Col 3
10	N/C

Switch #	Connection A	Connection B
1	PIN 1	PIN 7
2	PIN 1	PIN 8
3	PIN 1	PIN 9
4	PIN 2	PIN 7
5	PIN 2	PIN 8
6	PIN 2	PIN 9
7	PIN 3	PIN 7
8	PIN 3	PIN 8
9	PIN 3	PIN 9
*	PIN 4	PIN 7
0	PIN 4	PIN 8
#	PIN 4	PIN 9
<-	PIN 5	PIN 7
C	PIN 5	PIN 8
->	PIN 5	PIN 9

### P2 SERVICE

1	24VDC
2	UNDEDICATED RELAY OUTPUT
3	SHUTDOWN SWITCH
4	SHUTDOWN SWITCH SCAN
5	KEY
6	DOOR SWITCH
7	DOOR SWITCH SCAN

### P3 POWER

1	24 VAC
2	VAC COMMON
3	12 VAC
4	N/C
5	KEY
6	EARTH GROUND

### P4 MDB +

1	34VDC
2	PWR GND
3	8 VDC
4	MASTER RXD
5	MASTER TXD
6	COMMUNICATION COMMON

### P5 SERIAL INTERFACE

1	MASTER RECEIVE DATA
2	GND
3	MASTER TRANSMIT DATA
4	KEY
5	N/C
6	+5 VOLTS

### P6 DC MOTOR DRIVE

1	ROW 1 +
2	ROW 2 +
3	ROW 3 +
4	ROW 4 +
5	ROW 5 +
6	ROW 6 +
7	ROW 7 +
8	ROW 8 +
9	COL 0 -
10	COL 1 -
11	COL 2 -
12	KEY
13	COL 3 -
14	COL 4 -
15	COL 5 -
16	COL 6 -
17	COL 7 -
18	COL 8 -
19	COL 9 -
20	KEY
21	ROW 9
22	ROW 10

### P7 CHIP

1	INPUT/OUTPUT LINE
2	N/C
3	KEY
4	GND

### P8 FLIP

1	VCC
2	ALE
3	TXD
4	RXD
5	PSEN
6	GROUND

### P9 BATTERY

1	+
2	-

### P10 LIGHT RELAY

1	24VDC
2	LIGHT RELAY CONTROL

### P11 POSIVEND/COFFEE SELECTION

1	PV ENABLE 1/DATA OUT
2	PV SIGNAL 1/DATA IN
3	PV ENABLE 2/CLOCK
4	STROBE
5	PV GROUND/GROUND
6	KEY
7	PV POWER/8VDC
8	PV SIGNAL 2
9	GROUND

### P12 DISPLAY

1	GROUND
2	5VDC
3	N/C
4	RS
5	WR NOT
6	KEY
7	DB0

### P12 DISPLAY

8	DB1
9	DB2
10	DB3
11	DB4
12	DB5
13	DB6
14	DB7

## Fusion Chiller Control Board

P/N 80492751

### Board Layout and Connector Function

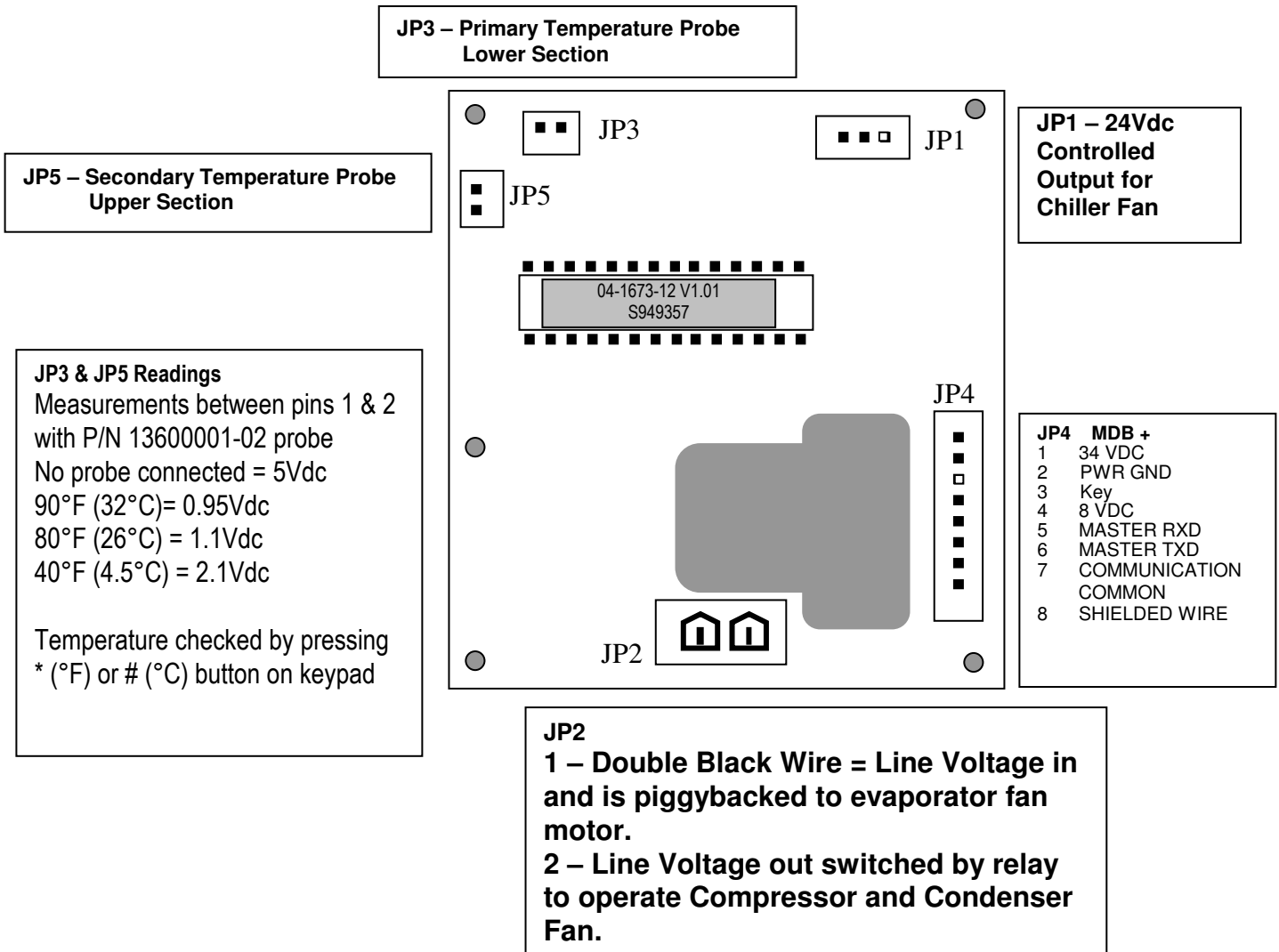

# Troubleshooting

<b>Error on display</b>	<b>Definition of Error</b>	<b>Possible Solutions</b>
<b>MOTOR ERRORS</b>		
MOTOR XXX DIDNT HOME	Vend motor Time Out - XXX represents the selection motor	Motor left the home position, and never returned in the allotted time <ul style="list-style-type: none"> <li>• Check for jammed product in spiral</li> <li>• Check for loose wire on motor</li> </ul>
MOTOR XXX STALLED	Vend motor Over Current	While the motor was running, the current used by the motor exceeded a pre-set threshold <ul style="list-style-type: none"> <li>• Check for jammed product in spiral</li> </ul>
MOTOR XXX OFF HOME	Vend motor Not Home	After the motor has been scanned by the board, and checked for an "at Home" condition, the motor is still not at home <ul style="list-style-type: none"> <li>• Check for a product jam</li> </ul>
BAFFLE x CURRENT	Baffle Motor Over Current – X indicates which cabinet	The baffle door in the Á LA CARTE has experienced an over current condition while attempting to open or close. <ul style="list-style-type: none"> <li>• Check baffle door rod for correct adjustment</li> <li>• Open door and inspect left and right track for dirt – clean as required</li> <li>• Check harness to motor for loose connections</li> <li>• Check for obstructions from delivery bin</li> </ul>
BAFFLE x TIMEOUT	Baffle Motor Timeout - X indicates which cabinet	Motor left the home position, and never reached the open position in the allotted time, or visa versa <ul style="list-style-type: none"> <li>• Check harness to open and closed position switch</li> <li>• Check switches for proper operation</li> <li>• Check pin on baffle door motor crank arm</li> </ul>
LOW VOLTAGE	Low voltage was detected during a Vend	This error will only appear during a vend. This error indicates that a pre-set low voltage threshold was reached for the motor supply circuit. <ul style="list-style-type: none"> <li>• Check the incoming 120Vac supply to the machine – must be within 10% - no lower than 108V</li> <li>• Check for other machines plugged to the same circuit as this machine – rearrange plugs if possible</li> </ul>

# Troubleshooting

<b>CONTROL BOARD &amp; SOFTWARE ERRORS</b>																																						
KEYPAD SW X STUCK	Keypad Switch X Stuck down <table border="1"> <thead> <tr> <th>Code</th> <th>Key</th> <th>Code</th> <th>Key</th> <th>Code</th> <th>Key</th> </tr> </thead> <tbody> <tr> <td>000</td> <td>1</td> <td>010</td> <td>2</td> <td>020</td> <td>3</td> </tr> <tr> <td>001</td> <td>4</td> <td>011</td> <td>5</td> <td>021</td> <td>6</td> </tr> <tr> <td>002</td> <td>7</td> <td>012</td> <td>8</td> <td>022</td> <td>9</td> </tr> <tr> <td>003</td> <td>*</td> <td>013</td> <td>0</td> <td>023</td> <td>#</td> </tr> <tr> <td>004</td> <td>&lt;</td> <td>014</td> <td>C</td> <td>024</td> <td>&gt;</td> </tr> </tbody> </table>	Code	Key	Code	Key	Code	Key	000	1	010	2	020	3	001	4	011	5	021	6	002	7	012	8	022	9	003	*	013	0	023	#	004	<	014	C	024	>	Either a key on the keypad is stuck or there is damage to the harness from the keypad to the logic board <ul style="list-style-type: none"> <li>• Check the keypad for a broken or damaged button</li> <li>• Check the harness for a pinched or shorted wire</li> </ul>
Code	Key	Code	Key	Code	Key																																	
000	1	010	2	020	3																																	
001	4	011	5	021	6																																	
002	7	012	8	022	9																																	
003	*	013	0	023	#																																	
004	<	014	C	024	>																																	
CABx COMM ERROR	Cabinet Communication error	The Logic Control Board (LCB) has lost communication to the FDB. <ul style="list-style-type: none"> <li>• Check the communications harness between the two boards for damage. If any damage is found, harness should be replaced</li> <li>• Check position of Cabinet Jumper on FDB (C1 or C2) for correct position</li> <li>• Power down and disconnect any MDB payment peripherals, restore power and see if error repeats.</li> </ul>																																				
RAM CHKSUM	RAM CHKSUM	This error will only appear during a power up cycle, and is the result of the contents of the flash memory not agreeing with the stored memory contents on the board. <ul style="list-style-type: none"> <li>• Inspect the board for any physical damage to the smaller flash chip</li> <li>• Access the service mode and perform a complete reset of the control board.</li> </ul>																																				
ROM CHKSUM	ROM CHKSUM	This message will only appear during a power up cycle. The memory contents of the microprocessor on the board have been corrupted, and are not recoverable. The control board must be replaced.																																				
SW TRAP ERROR – XX	Software Trap TBD																																					
TIME / DATE / BATT ERROR	Time and date have not been set. Battery has failed.	Set time and date. Replace battery.																																				

# Troubleshooting

TEMPERATURE SENSE ERRORS		
HEALTH SHUTDN CAB x	Health Shut down - X indicates which cabinet	This error indicates that the temperature inside the controlled cabinet has exceeded the maximum set temperature for a pre-set period of time. Check the Health Code Error for date and time of occurrence, along with duration and highest temperature reached.
TEMP CAB1 L ZN OPEN TEMP CAB1 H ZN OPEN TEMP CAB2 OPEN	Temperature Sensor CAB X YY ZONE Open X indicates which cabinet YY indicates upper (H ZN) or lower (L ZN)	The Refrigeration Driver Board (RDB) or Food Driver Board (FDB) has detected that the temperature sensor for one of the zones or cabinets is reporting a temperature reading which indicates the sensor is open <ul style="list-style-type: none"> <li>Check connections to the RDB – sensor should be plugged to board on JP3 for the lower section, and JP5 for the upper section, or P2 on the FDB</li> </ul>
TEMP CAB1 L ZN RANG TEMP CAB1 H ZN RANG TEMP CAB2 RANG	Temperature Sensor CAB X YY ZONE Out of Range X indicates which cabinet YY indicates upper (H ZN) or lower (L ZN)	The RDB or the FDB has detected that the temperature sensor for one of the zones or cabinets is reporting a temperature reading beyond a normal range <ul style="list-style-type: none"> <li>Check connections to the RDB – sensor should be plugged to board on JP3 for the lower section, and JP5 for the upper section, or P2 on the FDB</li> <li>Check the temperature probe harness for damage or a short</li> </ul>
TEMP X SENSOR BAD	Temperature Sensor error detected – X indicates which cabinet	This error reports a discrepancy in an À LA CARTE between the readings of the defrost bimetal and the temperature sensor. If the bimetal is closed, indicating the refrigeration unit is below 40°F, but the temperature sensor is reporting a temperature that is higher, and error is reported. Also would report an error if the opposite is true – the unit temperature is below 40°F, but the bimetal is open. This error can only occur after a health code period has elapsed. <ul style="list-style-type: none"> <li>Check P2 connector on FDB</li> <li>Check for physical damage to the sensor, or the harness</li> <li>Check the bimetal harness for damage</li> </ul>
CABx DEFROST ERROR	Defrost Timeout - X indicates which cabinet	A defrost error is reported when a defrost cycle in an À LA CARTE exceeds 30 minutes. The controller has terminated the defrost cycle, recorded the error, and turned the refrigeration unit back on. <ul style="list-style-type: none"> <li>Check defrost heater circuit for voltage and resistance or current draw.</li> <li>Check defrost relay for proper operation</li> <li>Check the defrost bimetal for proper operation – should open when temperature inside unit reached 50°F</li> </ul>
CABx SWITCH ERROR	Defrost Switch Error-X indicates which cabinet	A Switch error will only occur in a frozen À LA CARTE. This error occurs when upon entering a defrost cycle, the bimetal is checked and shows an open status while the temperature being reported is < 20°F. The error is posted, and a fixed 10 minute defrost cycle occurs. <ul style="list-style-type: none"> <li>Check defrost harness for damaged wire</li> <li>Verify operation of bimetal defrost sensor</li> </ul>

# Troubleshooting

POSIVEND ERRORS		
GOLDENEYE XXX FAILED	3 Items missed by the PosiVend Sensor. XXX indicates which selection.	Error would occur is a selection is empty, or if the spiral became disconnected from the motor. This error is reset if the machine door is opened and closed. The error will not be erased until errors are cleared
CABx GOLDENEYE ERROR	Three different selections in a cabinet missed by the PosiVend Sensor. X indicates which cabinet	As a result of 3 different selections reporting a PosiVend error, PosiVend has been disabled for the entire machine. This error is reset if the machine door is opened and closed. The error will not be erased until errors are cleared. Errors for each individual selection with a PosiVend error should be also reported.
CABx TRAN + REC BAD	All Transmitters and Receivers bad - X indicates which cabinet.	All receivers cannot see any of the transmitters <ul style="list-style-type: none"> <li>• Confirm ribbon cable between the two boards on the bin is correctly plugged in.</li> <li>• Check ribbon cable for damaged wires.</li> </ul>
CABx RECEIVER Y BAD	Receiver (Sensor) Y failed, Y indicates the number of the Sensor, X indicates which cabinet	Sensors are numbered on the PosiVend boards. Sensor 1 is closest to the inside of the machine through # 12 which is closest to the glass. <ul style="list-style-type: none"> <li>• Check for an obstruction to the specific sensor</li> <li>• Check for physical damage or moisture to the specific sensor</li> </ul>
CABx TRANSMTR Y BAD	Transmitter (LED) Y failed, Y indicates the number of the LED, X indicates which cabinet	The transmitter LEDs are numbered on the PosiVend boards. LED # 1 is closest to the glass through LED # 12 which is closest to the inside of the machine. <ul style="list-style-type: none"> <li>• Check for an obstruction to the specific LED</li> <li>• Check for physical damage or moisture to the specific LED</li> </ul>
CABx TRN Y TO REC Y	Transmitters Y not seen by a Receiver Y.	In a machine with PosiVend, each transmitter sends a beam across the delivery bin to each of the 12 receivers <ul style="list-style-type: none"> <li>• Check for an obstruction to the specific sensor or LED</li> <li>• Check for physical damage or moisture to the specific sensor or LED</li> </ul>

# Troubleshooting

---

<b>COIN MECHANISM ERRORS</b>		
DEFECTIVE TUBE SENSOR	The changer has detected one of the tube sensors behaving abnormally	Review documentation provided by coin mechanism manufacturer for specific instructions to resolve these errors
CM TUBE JAM	A tube payout attempt has resulted in jammed condition	
CM ROM CHECKSUM ERROR	The changers internal checksum does not match the calculated checksum.	
COIN JAM	A coin(s) has jammed in the acceptance path	
COIN ROUTING ERROR	A coin has been validated, but did not follow the intended routing.	
CREDITED COIN REMOVAL	There has been an attempt to remove a credited coin.	
<b>BILL VALIDATOR ERRORS</b>		
BV DEFECTIVE MOTOR	One of the BV motors has failed to perform its expected assignment.	Review documentation provided by bill validator manufacturer for specific instructions to resolve these errors
BV SENSOR PROBLEM	One of the BV sensors has failed to provide its response.	
BV ROM CHECKSUM ERROR	The validators internal checksum does not match the calculated checksum	
BILL REMOVED	A Credited bill in the escrow position has been removed by an unknown means.	
CASH BOX OUT OF POSITION	The validator has detected the cash box to be open or removed.	
<b>CASHLESS PAYMMENT SYSTEM ERRORS</b>		
CL PAYMENT MEDIA ERROR	Cashless Payment media Error	Review documentation provided by cashless system manufacturer for specific instructions to resolve these errors
CL INVALID MEDIA	Cashless Invalid Payment media	
CL TAMPER ERROR	Cashless Tamper Error	
CL REFUND ERROR	Cashless Internal reader credit lost	
CL COMMUNICATIONS ERROR	Cashless Communications Error	
CL REQUIRES SERVICE	Cashless Reader Requires Service	
CL FAILURE	Cashless Reader Failure	
CL MEDIA JAMMED	Cashless Payment media Jammed	



# Zone Combo – Software Update Instructions

## Fusion - Software Update Instructions Using a new Flash Memory Chip



**CAUTION:** The system components in this machine utilize static sensitive components. Precautions for handling sensitive devices should be observed when handling these items.

1. Note any required meter readings or options set.
2. Turn the power switch off.
3. Use a grounding strap and proper anti-static procedures to avoid Electro Static Discharge (ESD) that could damage components on the board.
4. Remove all harnesses from the board except the ribbon cable to the Selection Switches (P1), Display (P12) and Chip (P7).
5. Remove the one screw from the board cover located on the top horizontal edge of the board cover.
6. Remove the board cover by lifting the board cover upward over the latches and pulling forward.
7. Identify the Flash Memory Socket, remove the old software and install the revised software.

**NOTE:** Pay special attention to the alignment notch when installing the chip to prevent damage to either the chip or the socket! Three of the corners have square edges and one edge is cut at an angle, the angled corner lines up with the alignment notch as shown. Press the Flash Memory chip firmly into the socket.

8. Re-install the board cover and all harnesses.
9. Turn the power switch back on.
10. Press the mode button on the board. Enter the reset code 89171819 on the selection keypad, this will reset all options and prices back to factory defaults and reset all accountability back to zero.
11. Press and hold the switch on the top of the door until the "No row \* message" appears.
12. Set prices, options, and test.

**Fusion Board**  
Shown as installed  
in machine.

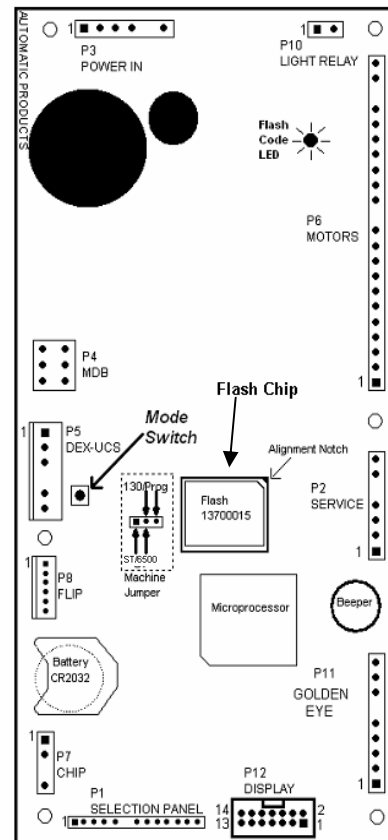

# Schematic

ZC 6600, REV.1.0, AUGUST 07

